

VISTA SUPERIOR

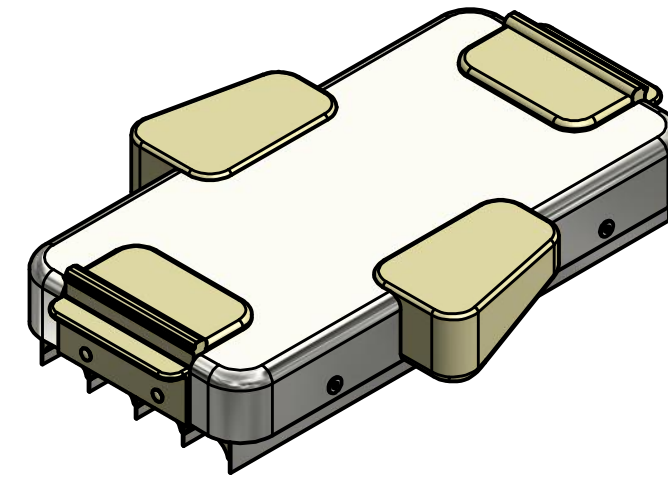

ISOMETRÍA

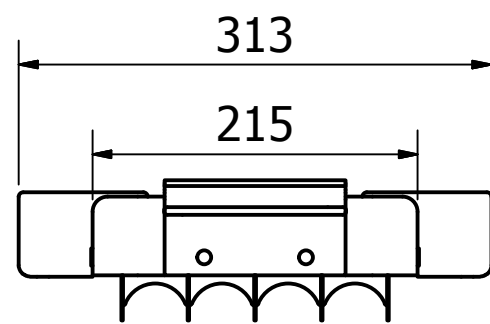

VISTA FRONTAL

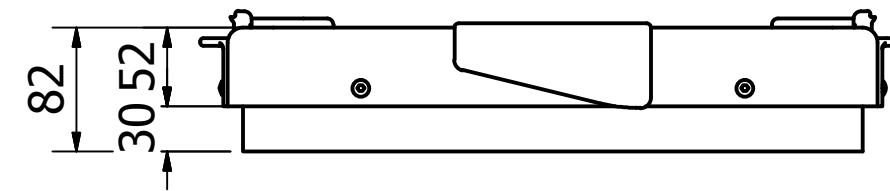

VISTA LATERAL DERECHA

TRABAJO DE FIN DE CARRERA			
	Carrera de Diseño de Productos		Isaac Díaz
	Contiene Vistas generales e isometría		Director D.H
	Medidas en mm	20/09/2017	Escala 1:5
			1 de 19

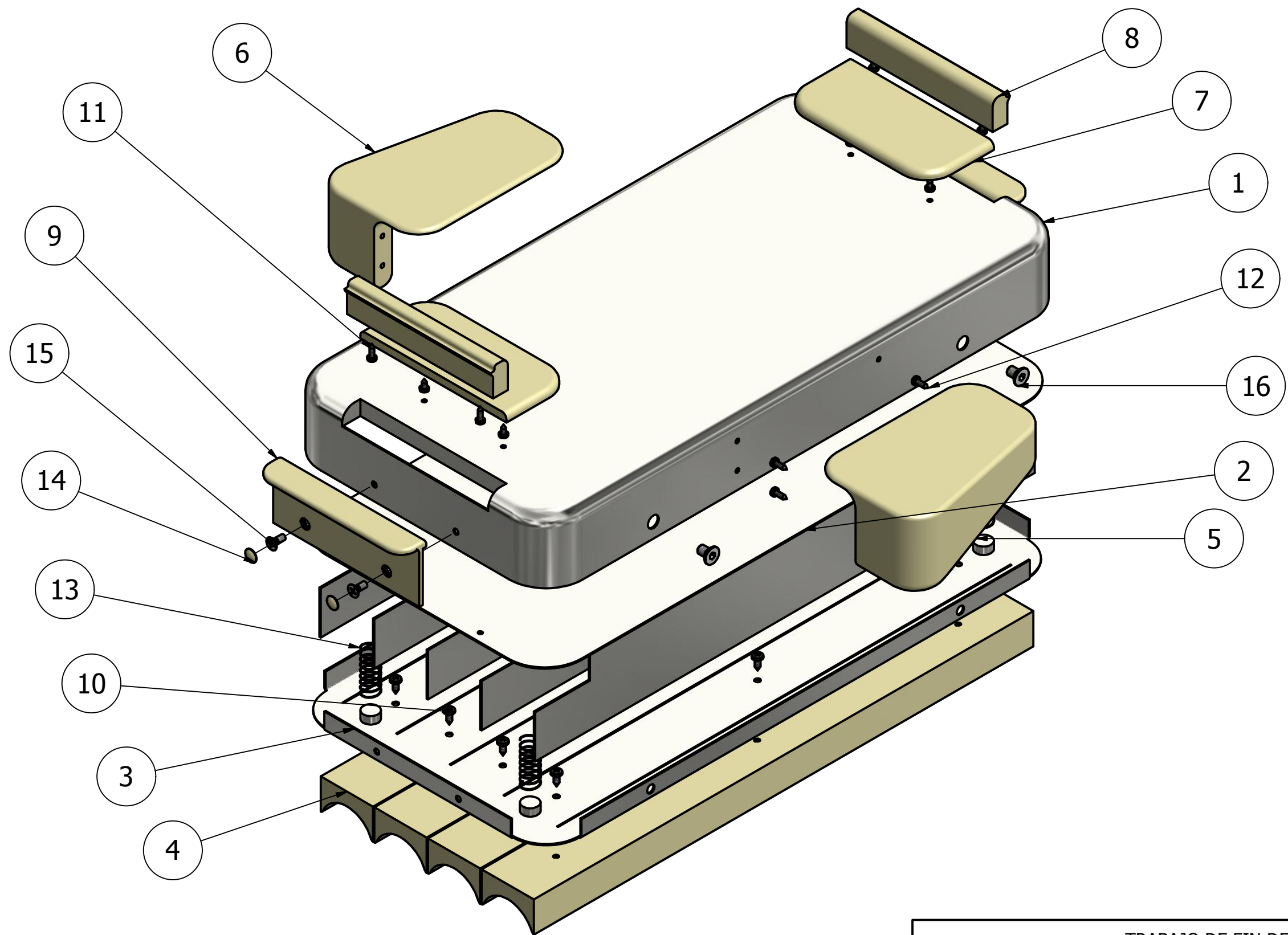

TRABAJO DE FIN DE CARRERA			
	Carrera de Diseño de Productos		Isaac Díaz
	Contiene Despiece del divisor boleador		Director D.H
	Medidas en mm	20/09/2017	Escala 1:2,5
			2 de 19

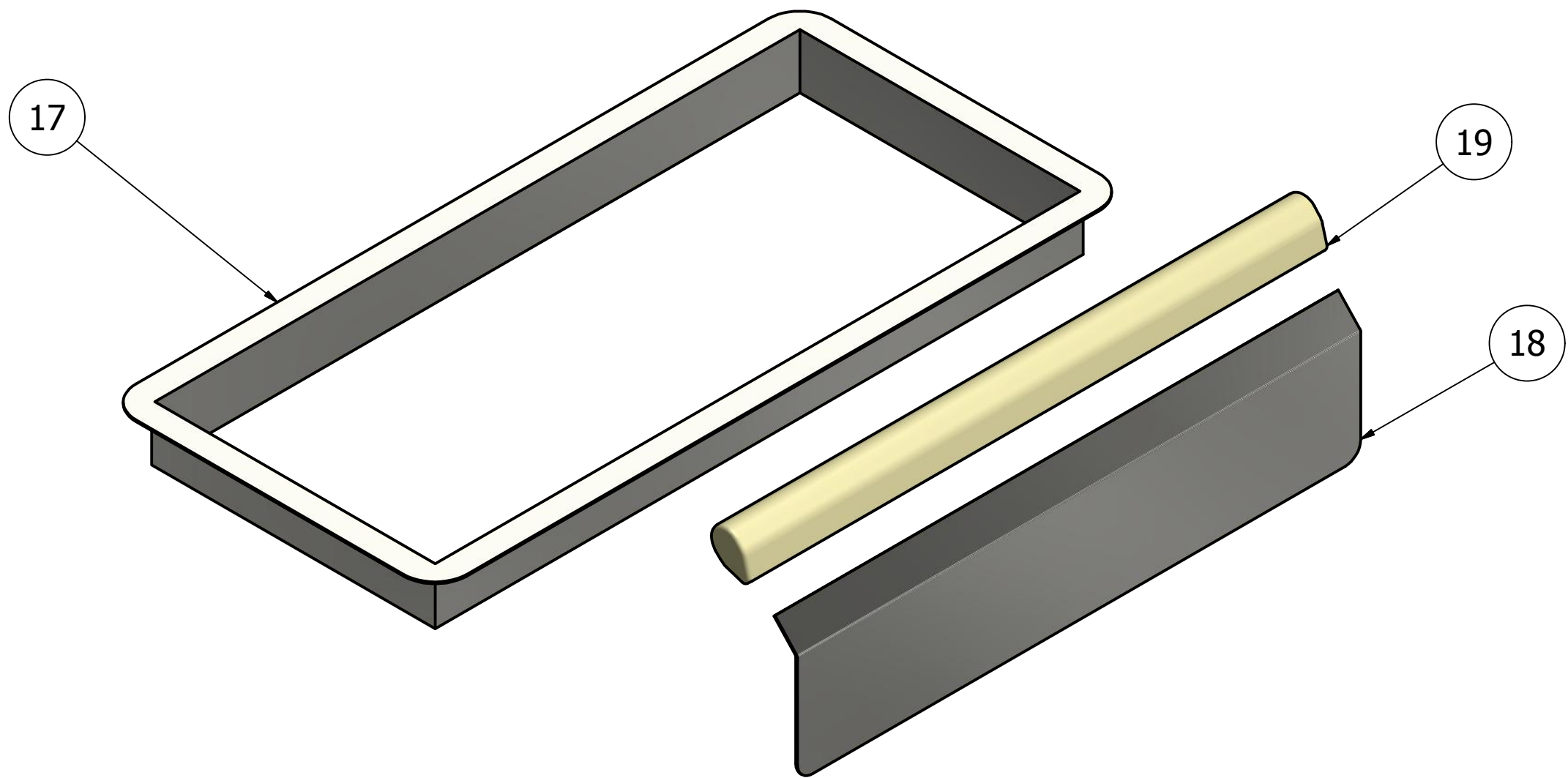

TRABAJO DE FIN DE CARRERA			
	Carrera de Diseño de Productos		Isaac Díaz
	Contiene Contenedor y despiece del separador		Director D.H
	Medidas en mm	20/09/2017	Escala 1:2,5
			3 de 19

LISTA DE PARTES			
Número de pieza	Cantidad de piezas	Nombre de la pieza	Descripción
1	1	Carcasa	Acero inoxidable AISI-304L de 1 mm de espesor embutido
2	1	Estructura de paredes de boleó	Acero inoxidable AISI-304L de 1 mm de espesor soldado
3	1	Estructura principal	Acero inoxidable AISI-304L de 1 mm de espesor doblado y perforado
4	4	Cuerpo cóncavo generador de bolas	Polímero grilon
5	1	Agarradera de boleó derecha	Polímero grilon
6	1	Agarradera de boleó izquierda	Polímero grilon
7	2	Apoyo de presión	Polímero grilon
8	2	Apoyo generador de paredes	Polímero grilon
9	2	Jaladera	Polímero grilon
10	12	Tornillo de cabeza redonda ISO 7049 - ST 3.5 x 9.5 - C - H	Acero inoxidable
11	8	Tornillo de cabeza redonda ISO 7049 - ST 2,9 x 6,5 - C - Z	Acero inoxidable
12	6	Tornillo de cabeza redonda ISO 7049 - ST 2,9 x 9,5 - C - Z	Acero inoxidable
13	4	Resorte	Acero inoxidable
14	4	Tapa de tornillo	Plástico
15	4	Tornillo de cabeza avellanada ISO 7046-1 - M4 x 10 - 4.8 - HISO	Acero inoxidable
16	4	Tornillo de cabeza avellanada ISO 10642 - M6 x 10	Acero inoxidable
17	1	Bastidor	Acero inoxidable AISI-304L de 1 mm de espesor soldado
18	1	Separador de masa	Acero inoxidable AISI-304L de 1 mm de espesor doblado
19	1	Soporte de agarre del separador	Polímero grilon

TRABAJO DE FIN DE CARRERA			
	Carrera de Diseño de Productos		Isaac Díaz
	Contiene LISTA DE PARTES		Director D.H
	Medidas en mm	20/09/2017	Escala
			4 de 19

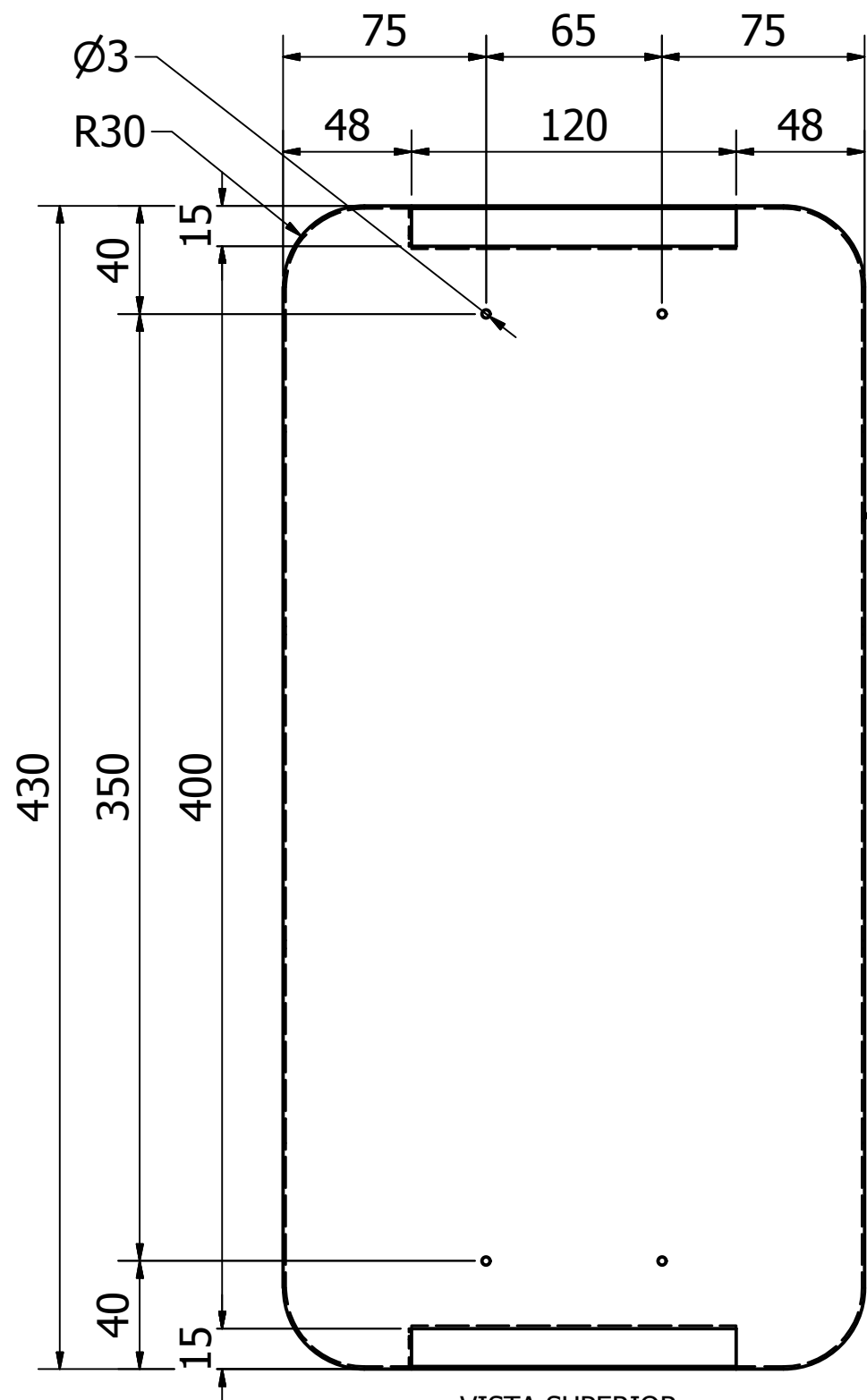

Espesor: 1 mm

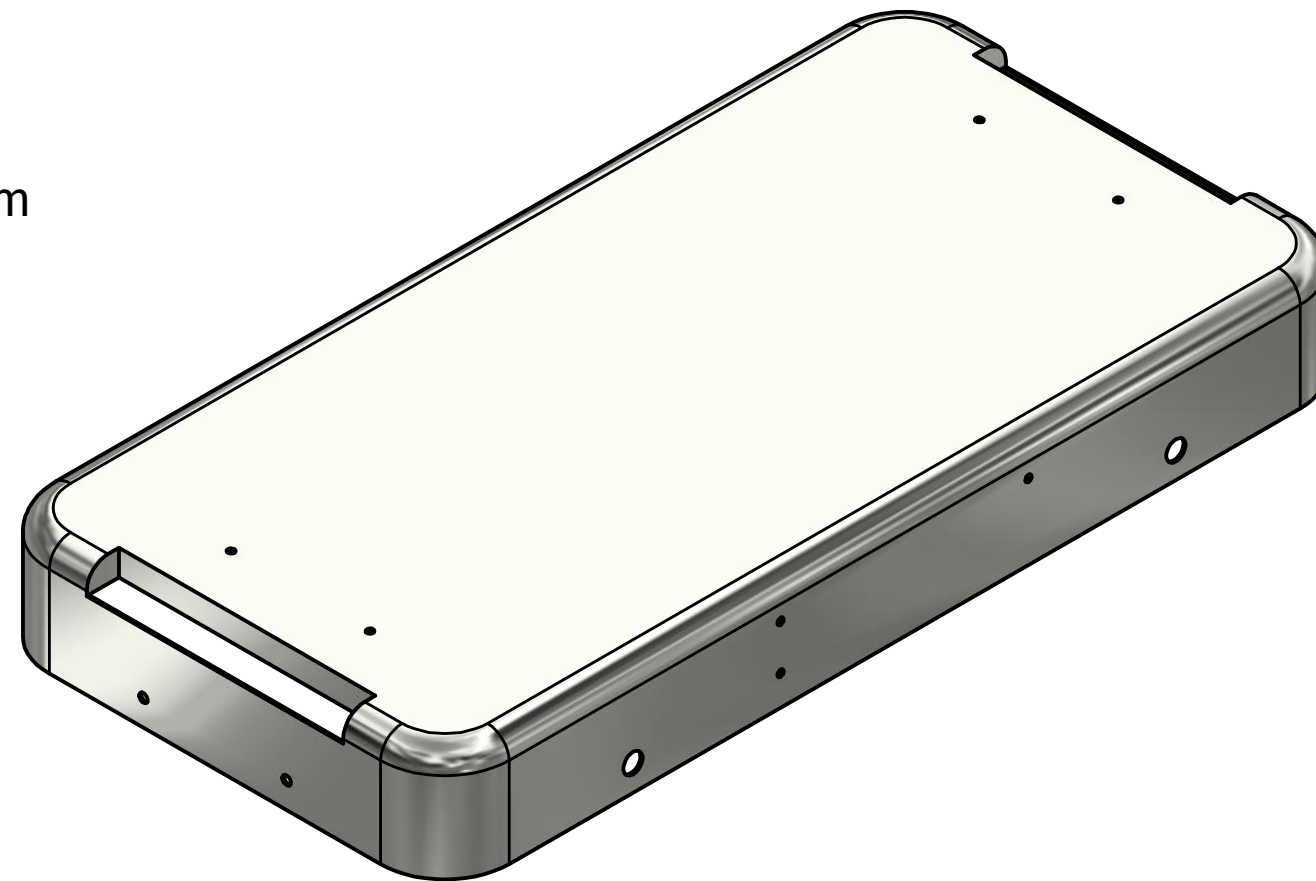

ISOMETRIA

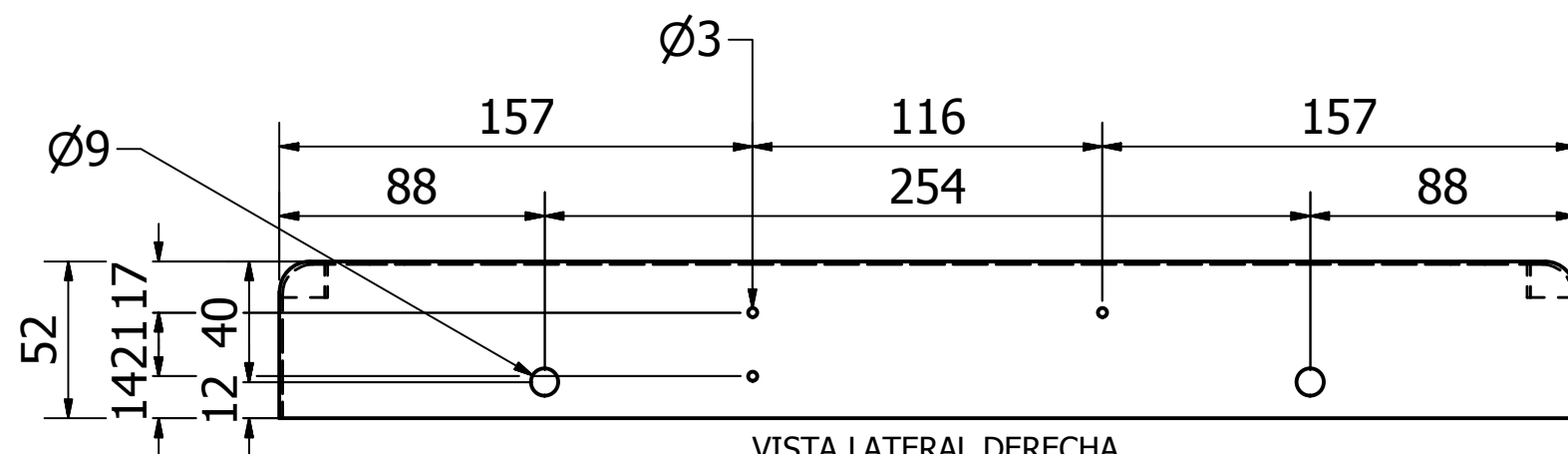

VISTA LATERAL DERECHA

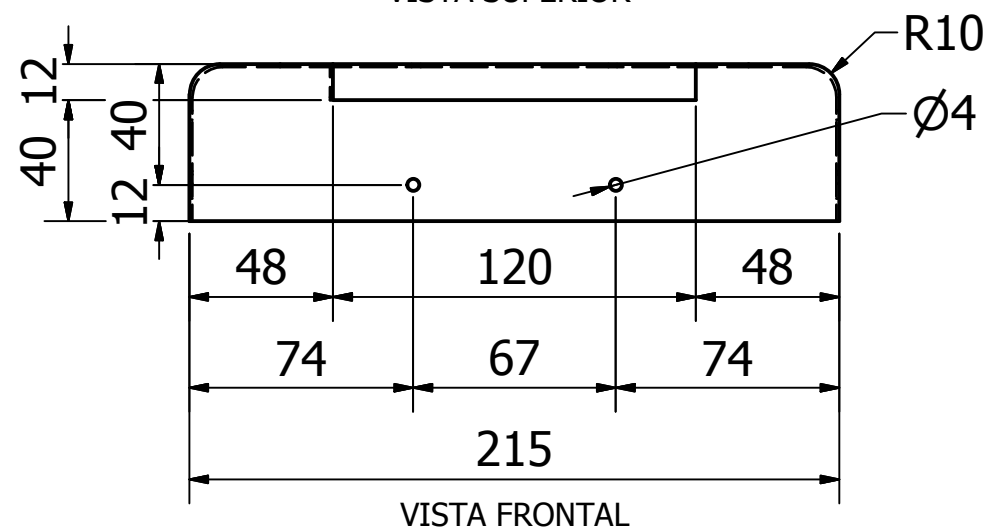

VISTA FRONTAL

TRABAJO DE FIN DE CARRERA			
	Carrera de Diseño de Productos		Isaac Díaz
	Contiene 1._ Carcasa		Director D.H
	Medidas en mm	20/09/2017	Escala 1:2,5
			5 de 19

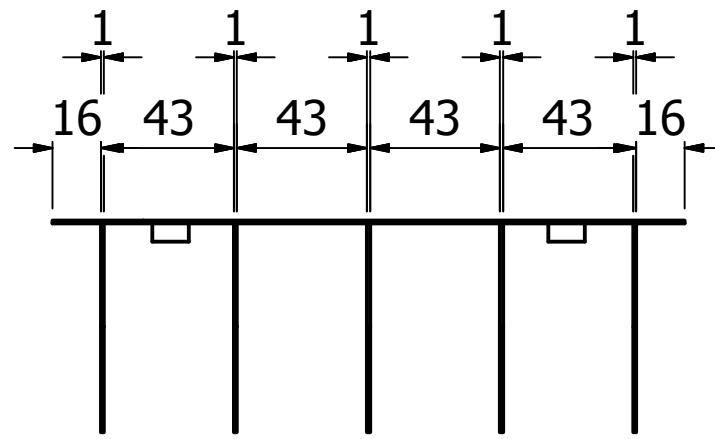

VISTA FRONTAL

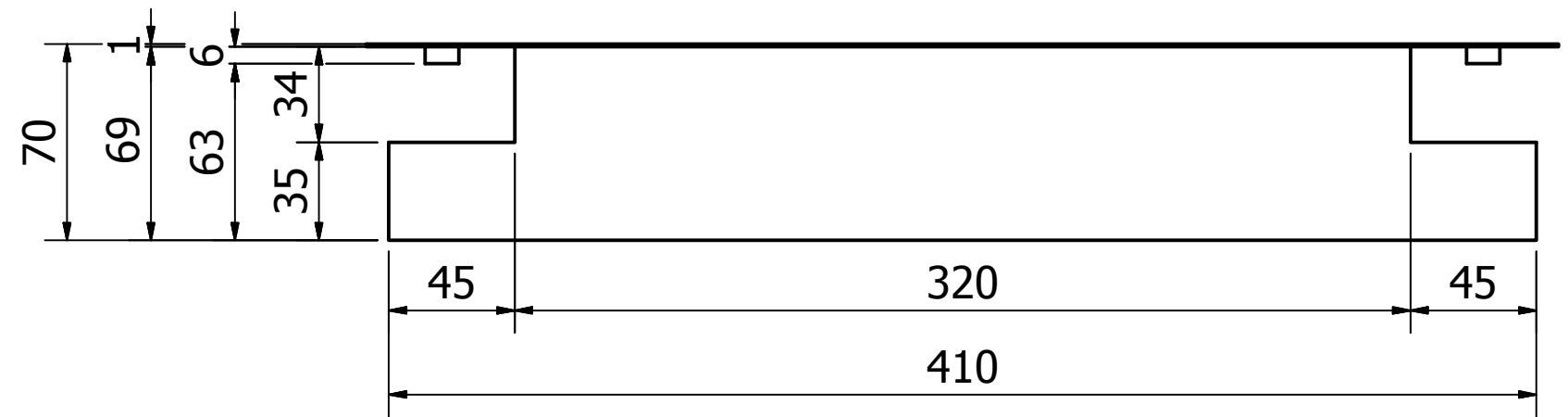

VISTA LATERAL DERECHA

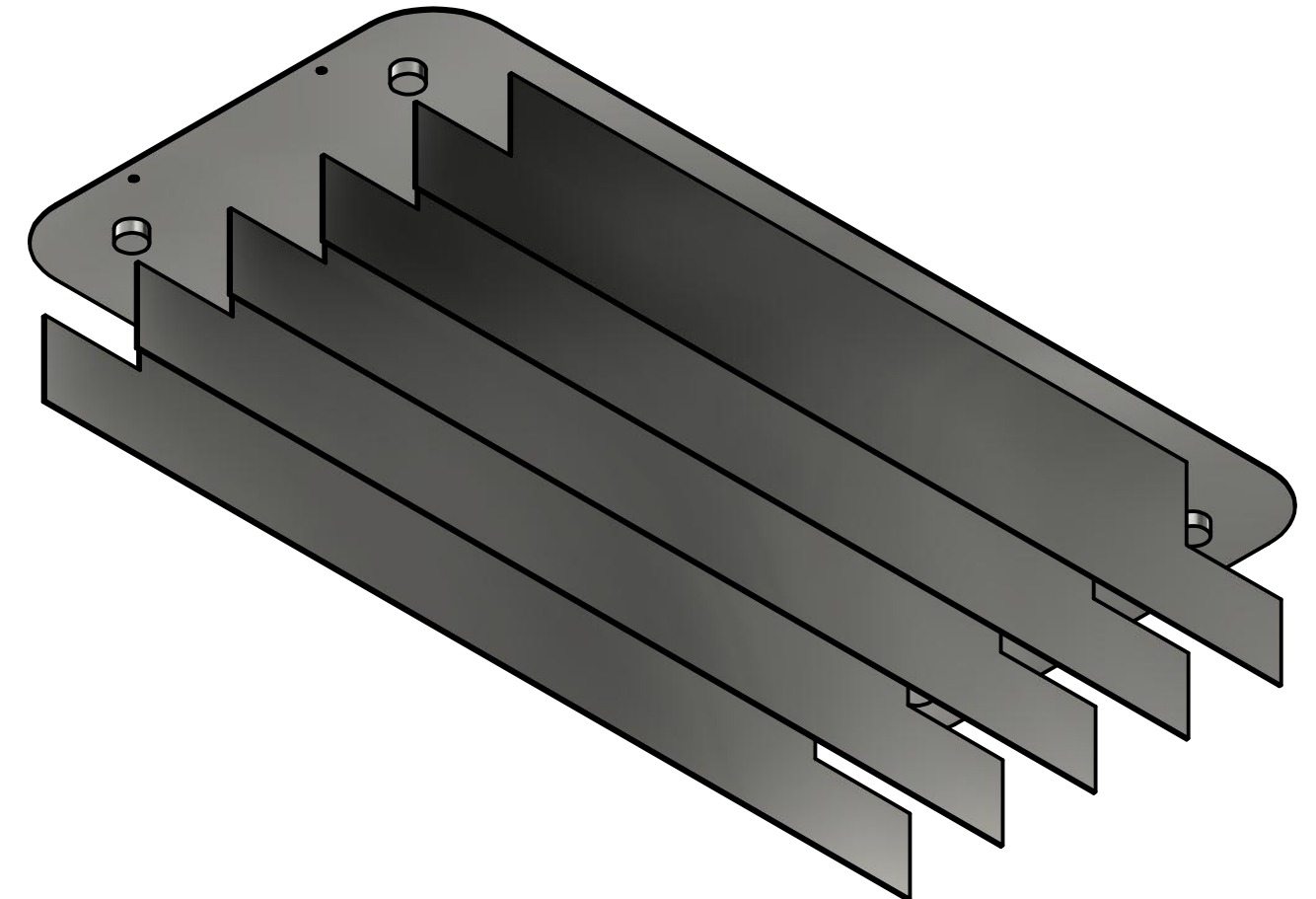

ISOMETRÍA

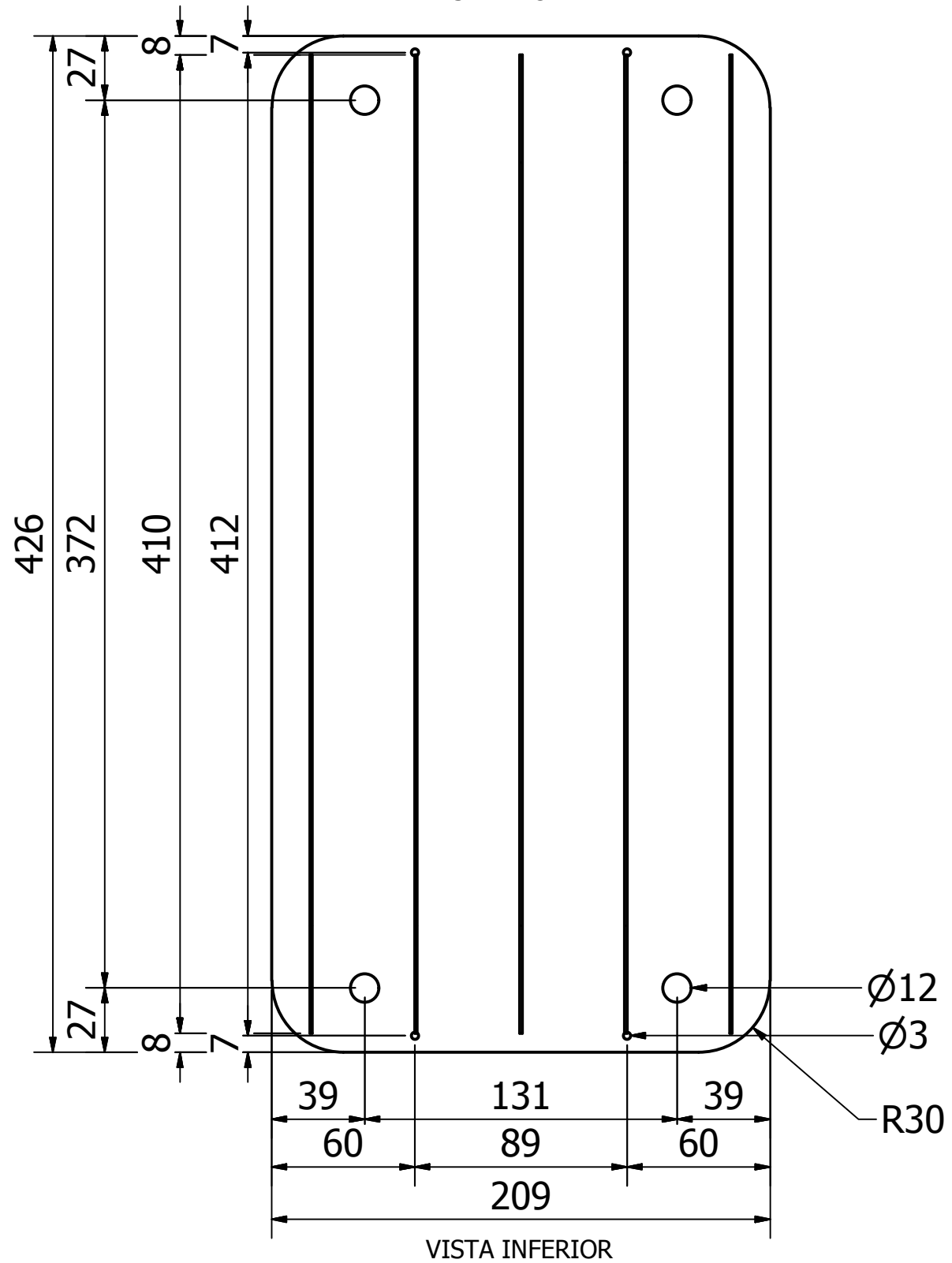

VISTA INFERIOR

TRABAJO DE FIN DE CARRERA			
	Carrera de Diseño de Productos		Isaac Díaz
	Contiene 2._ Estructura de paredes de boleo		Director D.H
	Medidas en mm	20/09/2017	Escala 1:2,5
			6 de 19

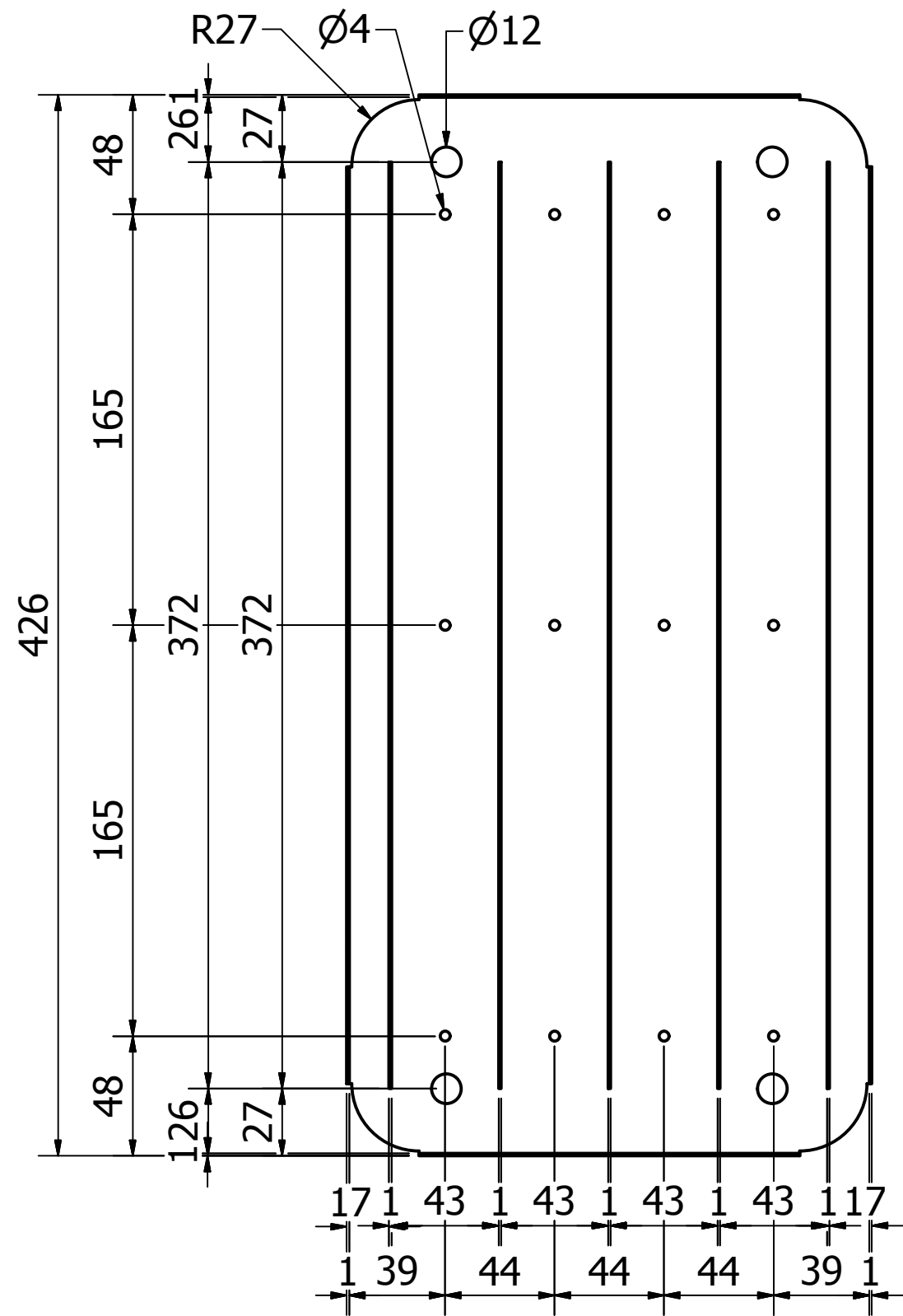

VISTA SUPERIOR

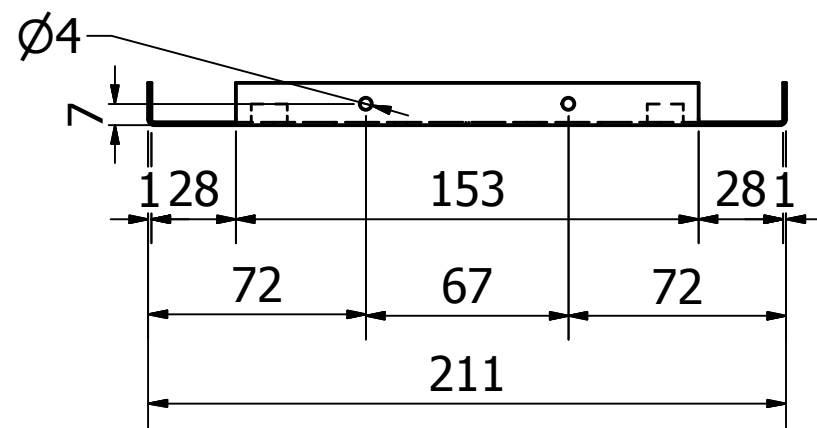

VISTA FRONTAL

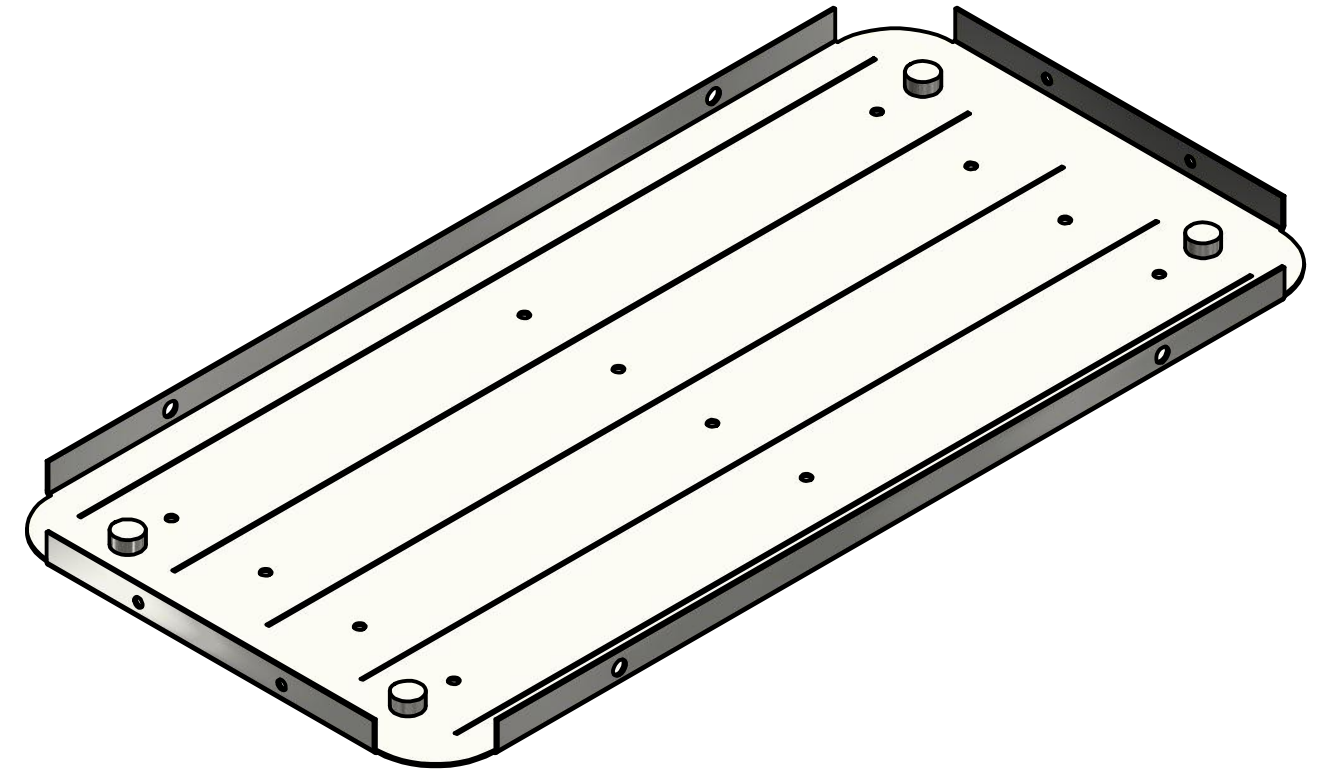

ISOMETRÍA

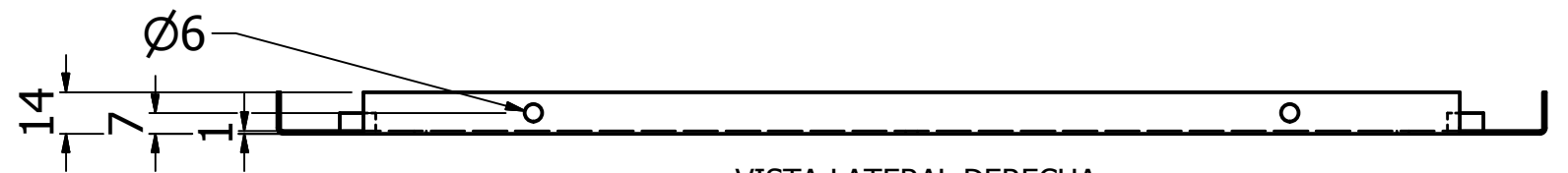

VISTA LATERAL DERECHA

TRABAJO DE FIN DE CARRERA			
	Carrera de Diseño de Productos		Isaac Díaz
	Contiene 3._ Estructura principal		Director D.H
	Medidas en mm	20/09/2017	Escala 1:2,5
			7 de 19

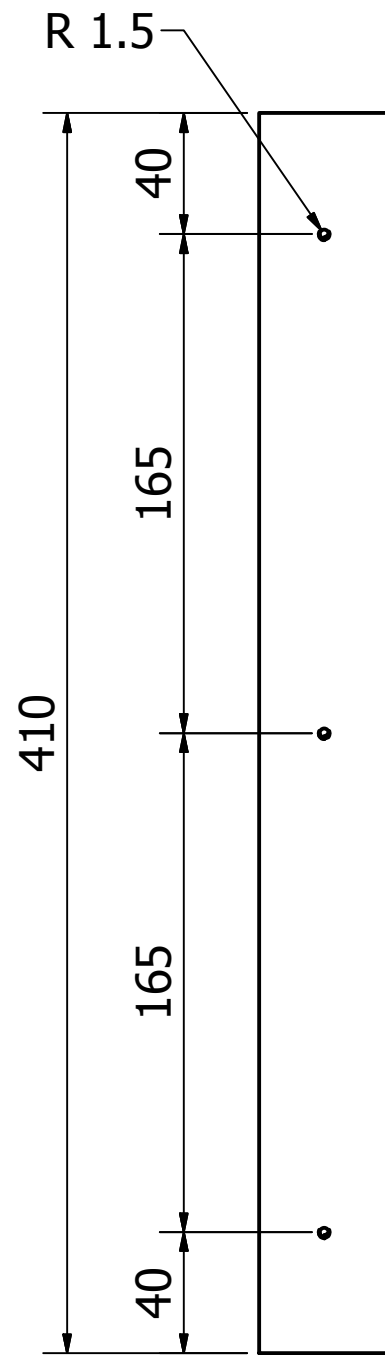

VISTA SUPERIOR

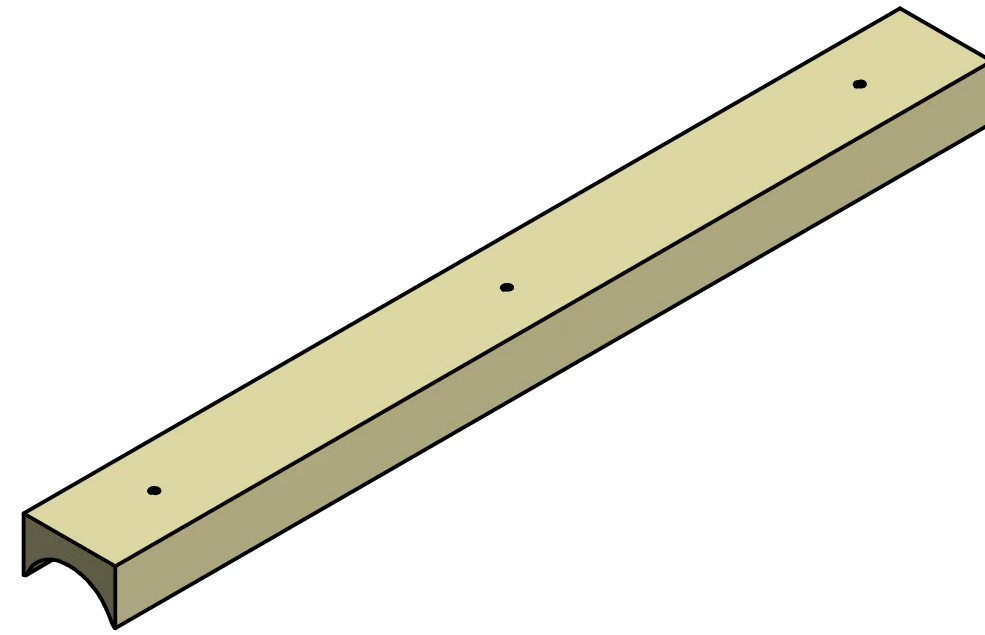

ISOMETRÍA

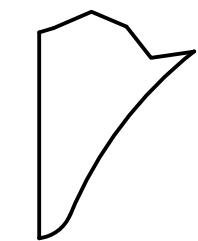

DETALLE M
ESCALA 2,5: 1

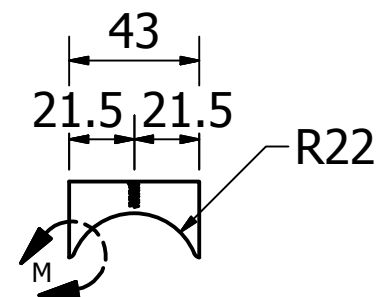

VISTA FRONTAL

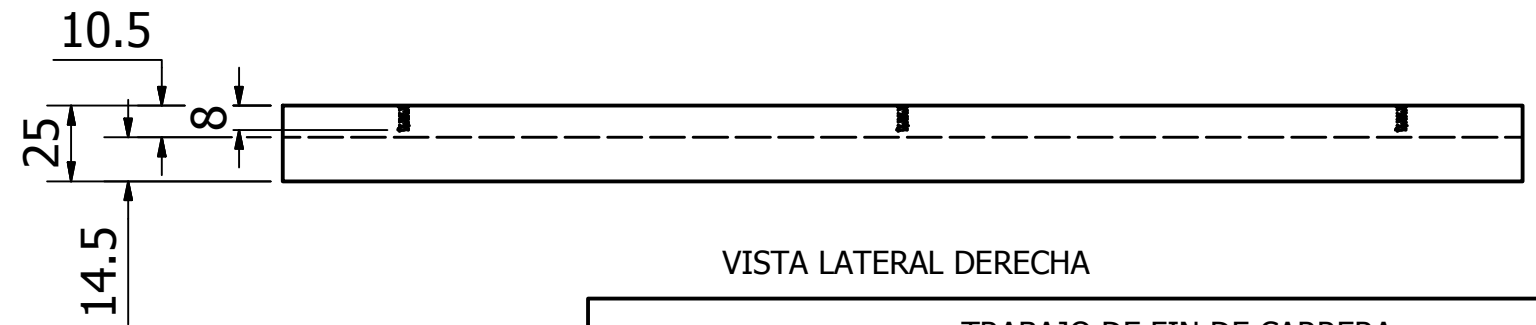

VISTA LATERAL DERECHA

TRABAJO DE FIN DE CARRERA			
	Carrera de Diseño de Productos		Isaac Díaz
	Contiene 4._ Cuerpo cóncavo generador de bolas		Director D.H
	Medidas en mm	20/09/2017	Escala 1:2,5
			8 de 19

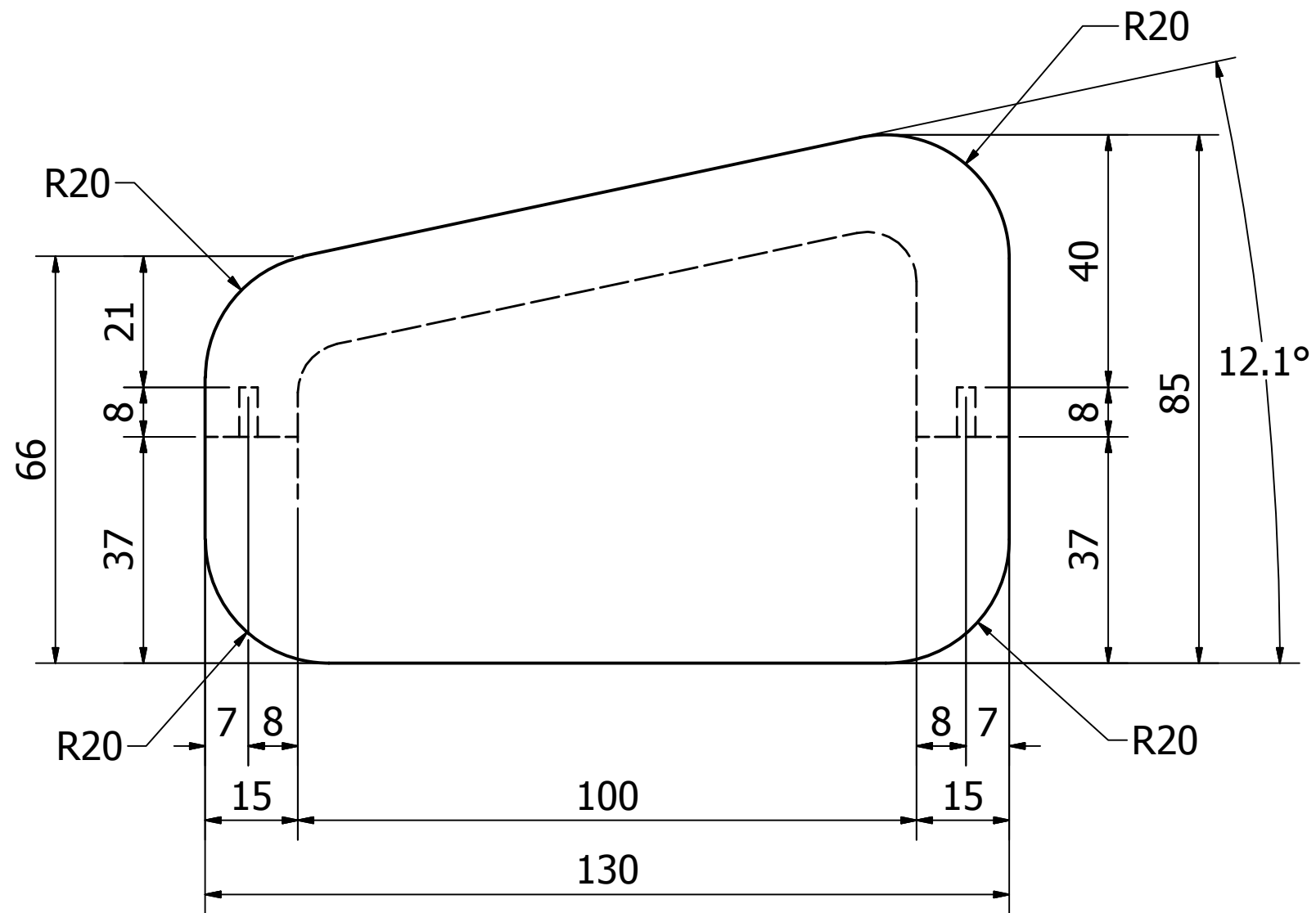

VISTA SUPERIOR

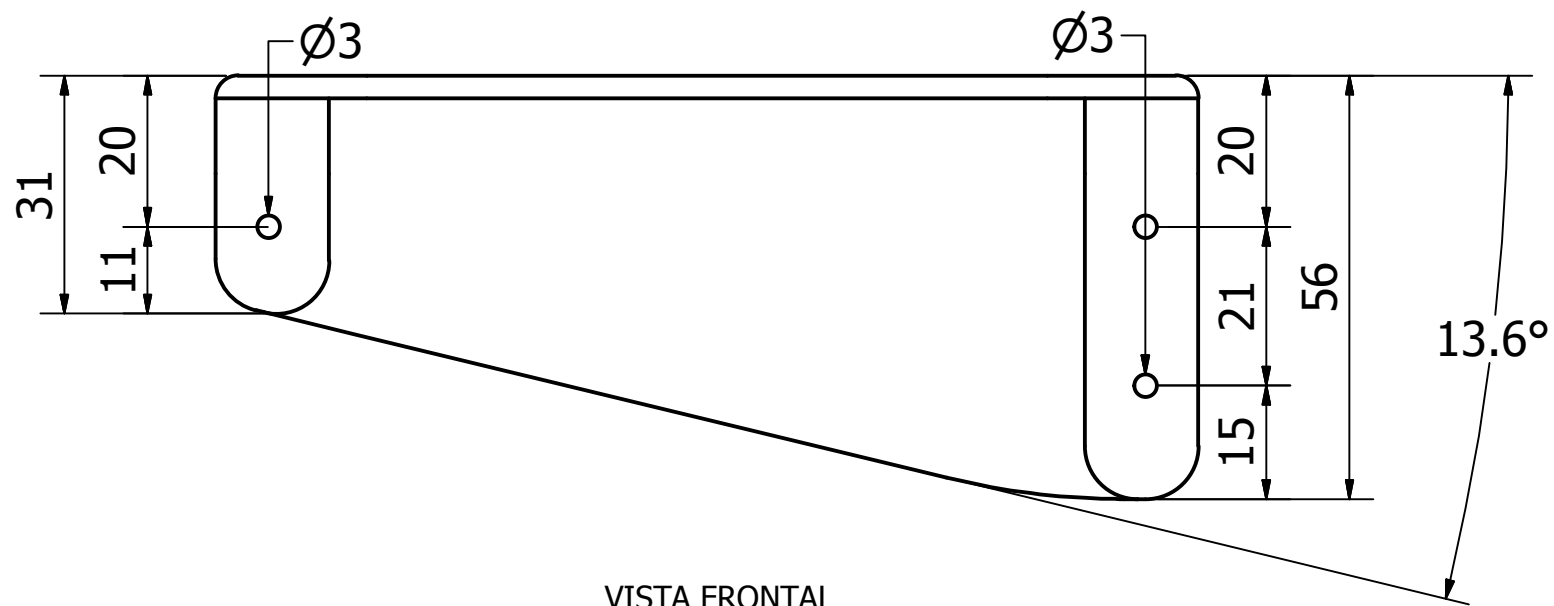

VISTA FRONTAL

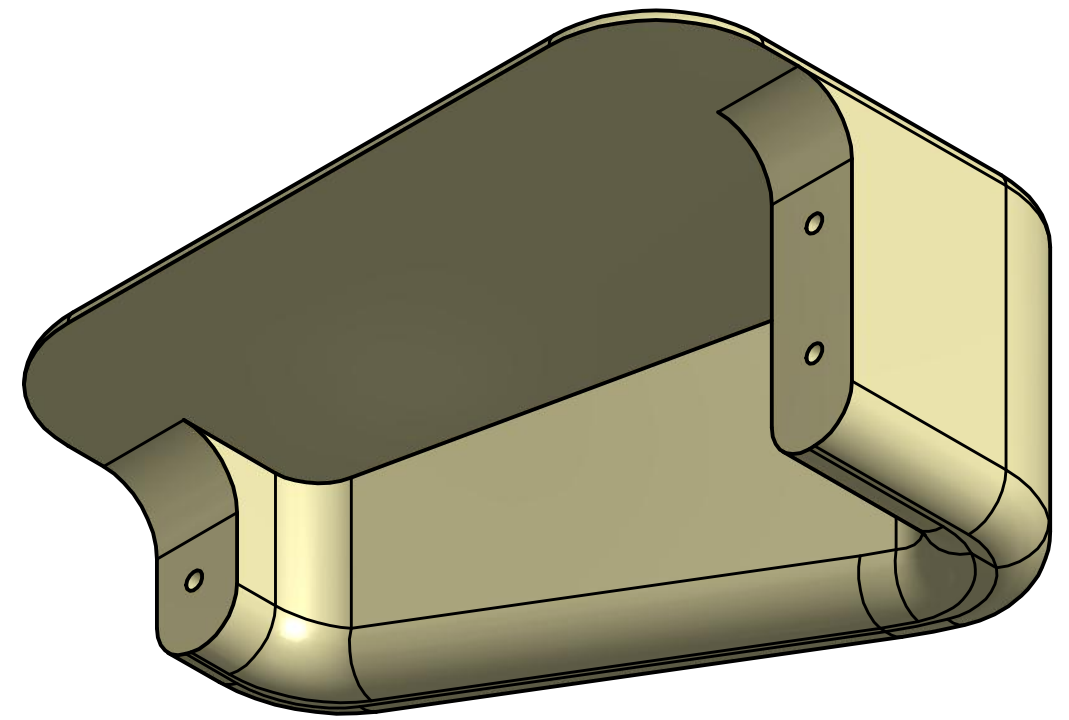

ISOMETRÍA

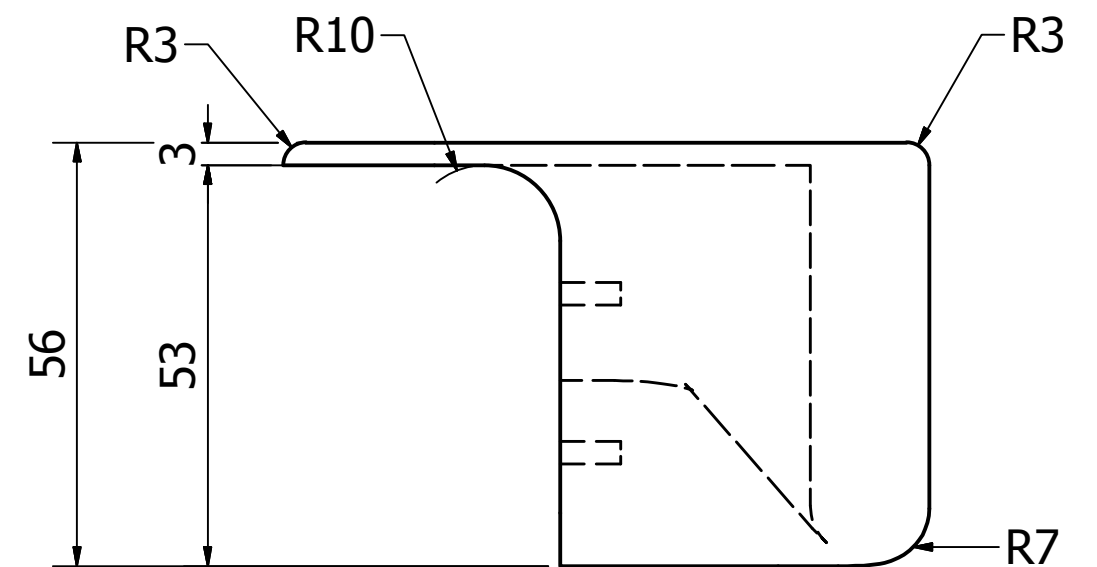

VISTA LATERAL DERECHA

TRABAJO DE FIN DE CARRERA			
	Carrera de Diseño de Productos		Isaac Díaz
	Contiene 5._ Agarradera de boleo derecha		Director D.H
	Medidas en mm	20/09/2017	Escala 1:1
			9 de 19

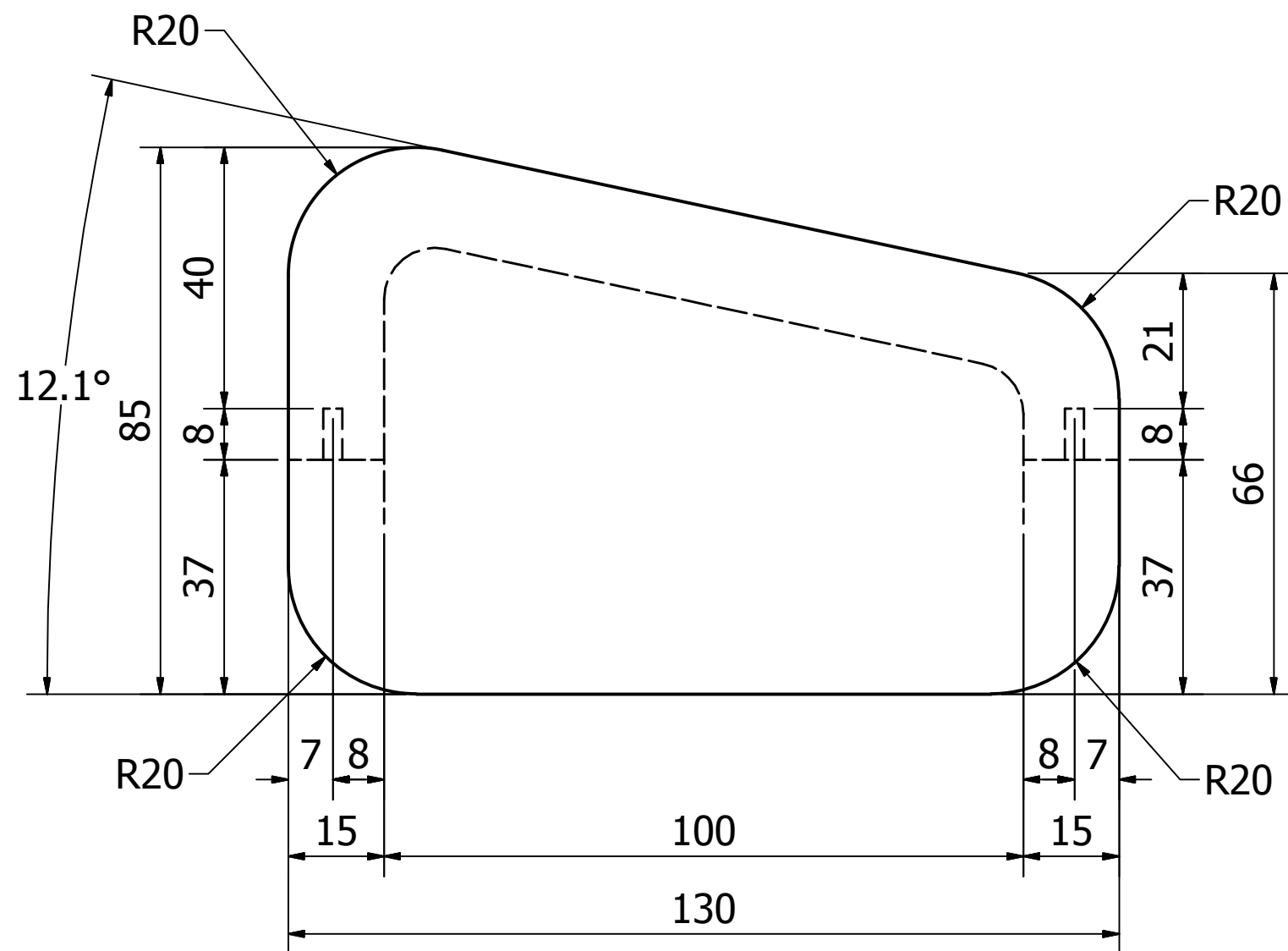

VISTA SUPERIOR

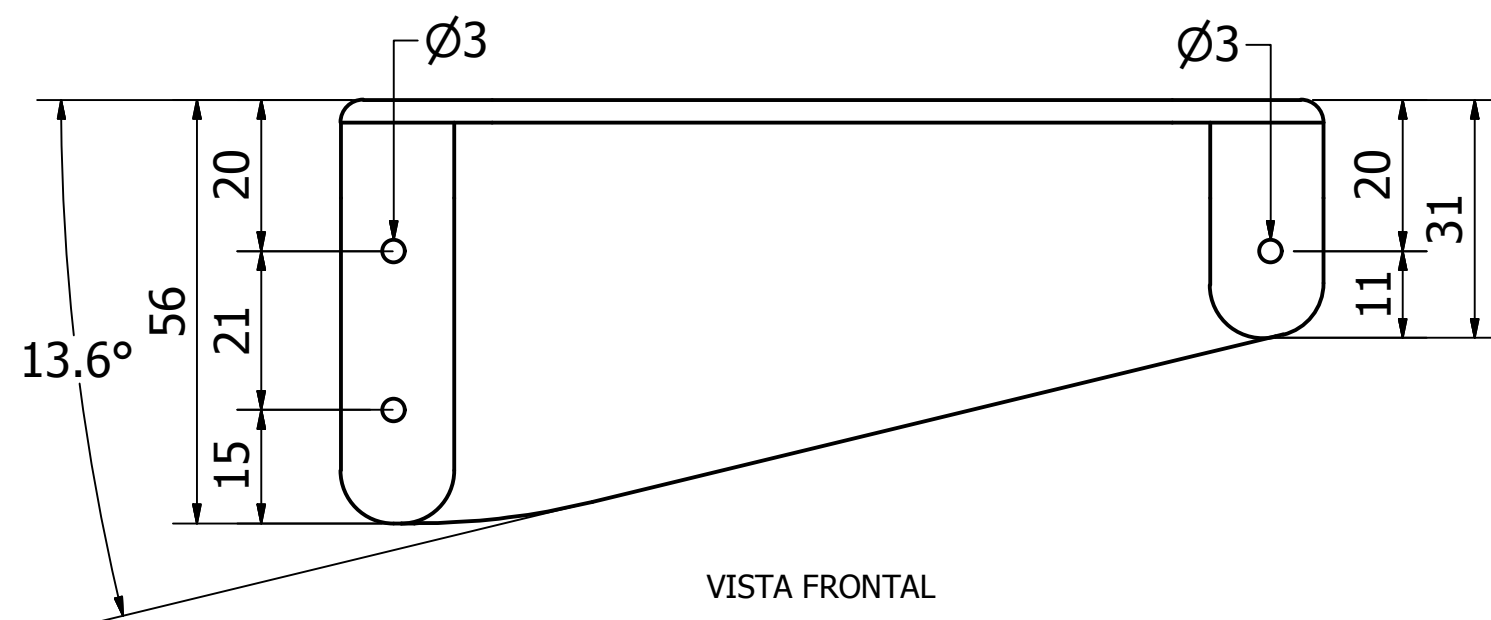

VISTA FRONTAL

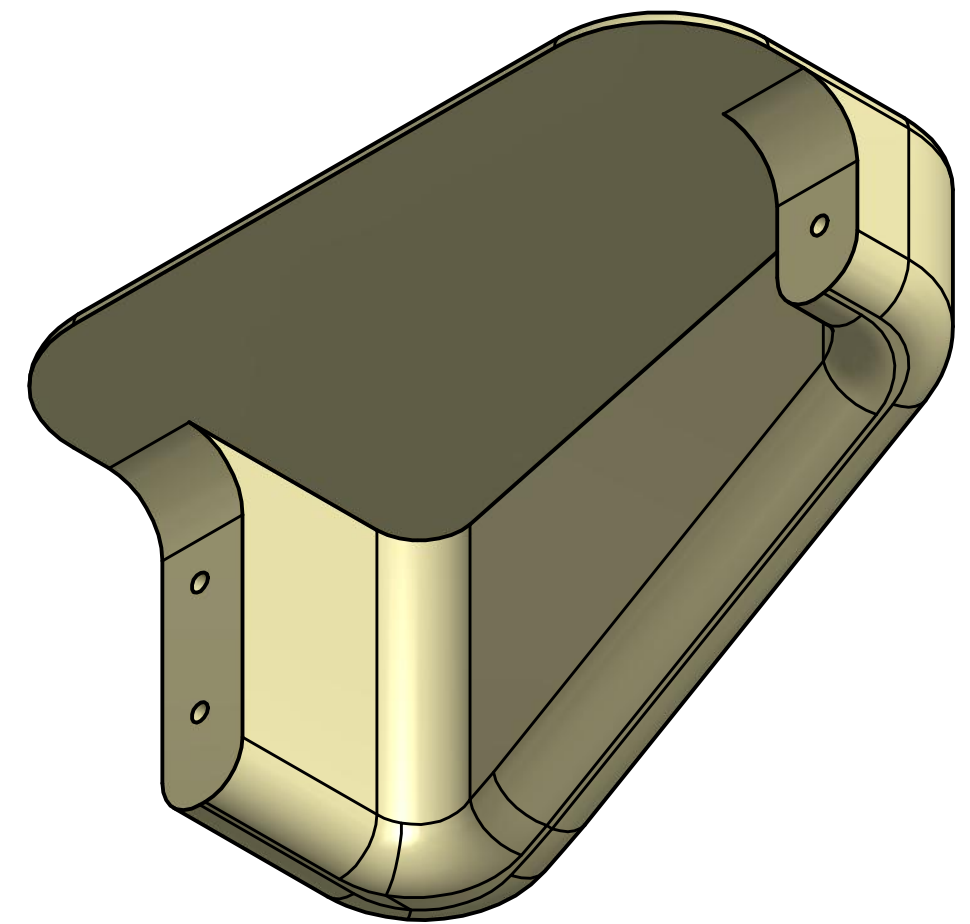

ISOMETRIA

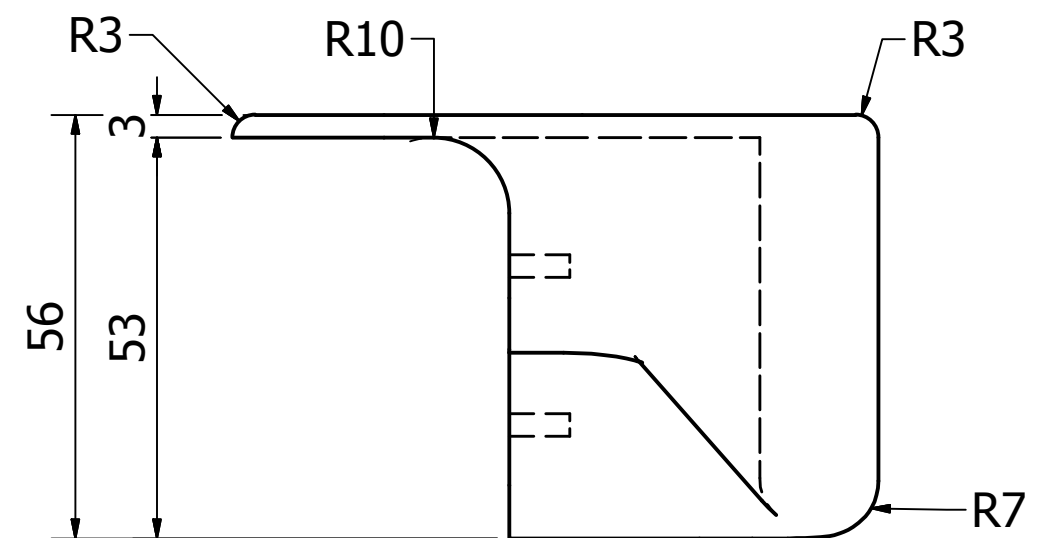

VISTA LATERAL DERECHA

TRABAJO DE FIN DE CARRERA			
	Carrera de Diseño de Productos		Isaac Díaz
	Contiene 6._ Agarradera de boleo izquierda		Director D.H
	Medidas en mm	20/09/2017	Escala 1:1
			10 de 19

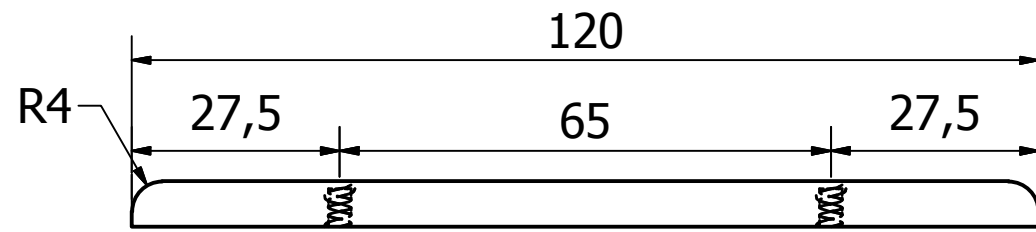

VISTA FRONTAL

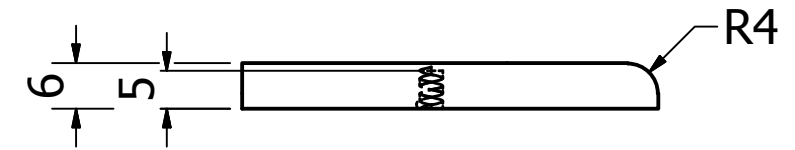

VISTA LATERAL DERECHA

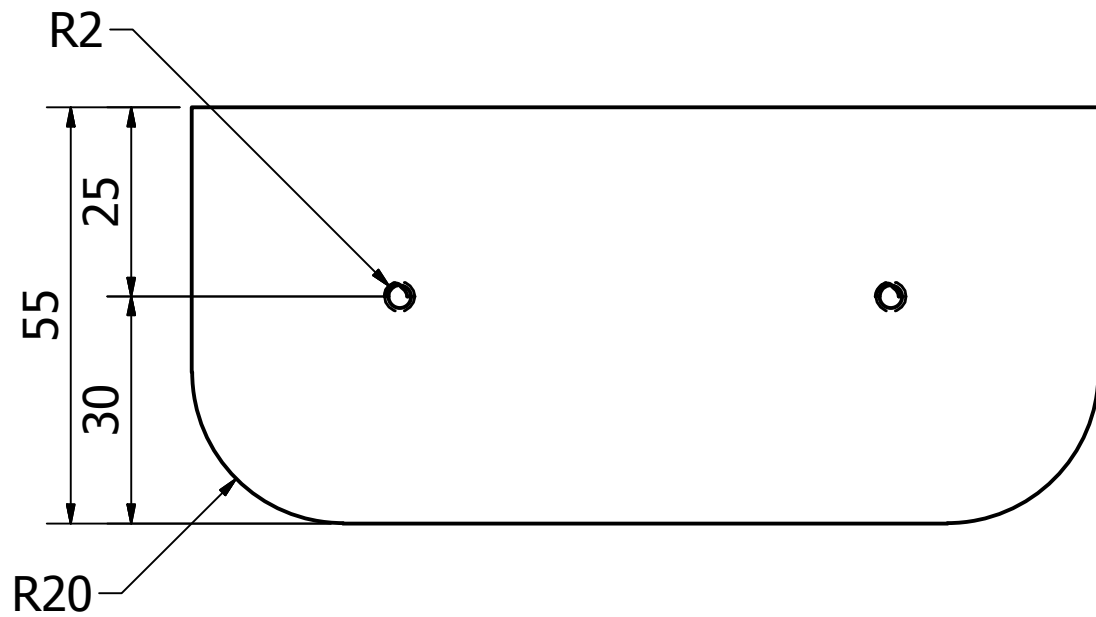

VISTA INFERIOR

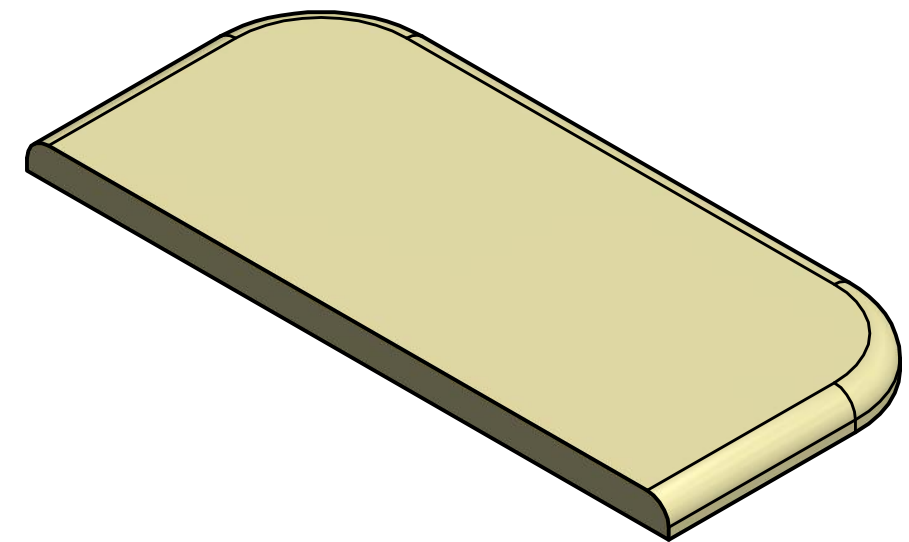

ISOMETRÍA

TRABAJO DE FIN DE CARRERA			
	Carrera de Diseño de Productos		Isaac Díaz
	Contiene 7._ Apoyo de presión		Director D.H
	Medidas en mm	20/09/2017	Escala 1:1
			11 de 19

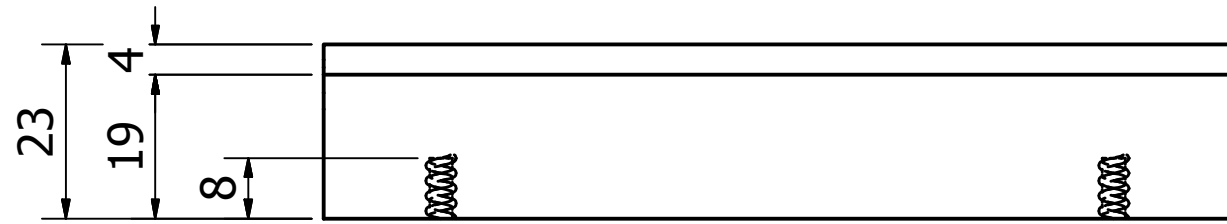

VISTA FRONTAL

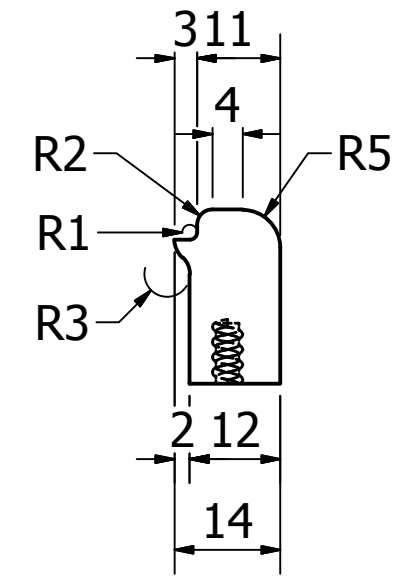

VISTA LATERAL DERECHA

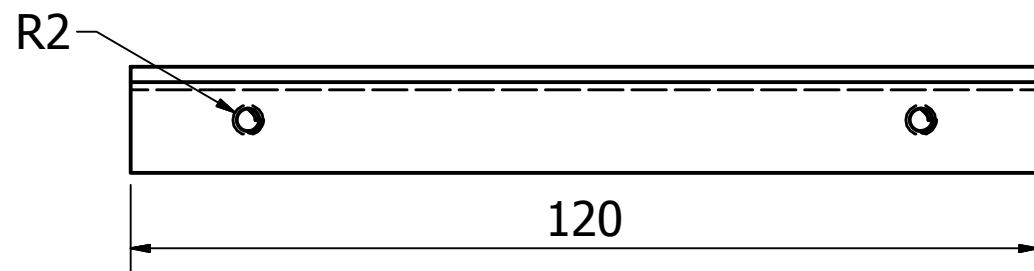

VISTA INFERIOR

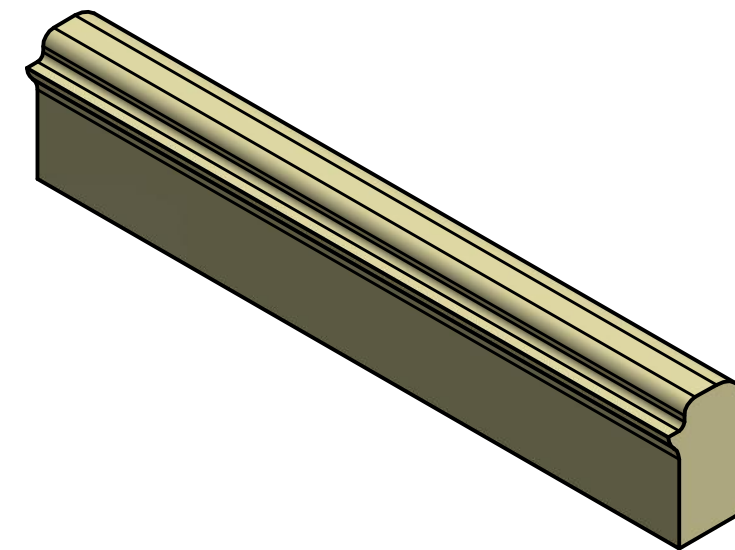

ISOMETRÍA

TRABAJO DE FIN DE CARRERA			
	Carrera de Diseño de Productos		Isaac Díaz
	Contiene 8._ Apoyo generador de paredes		Director D.H
	Medidas en mm	20/09/2017	Escala 1:1
			12 de 19

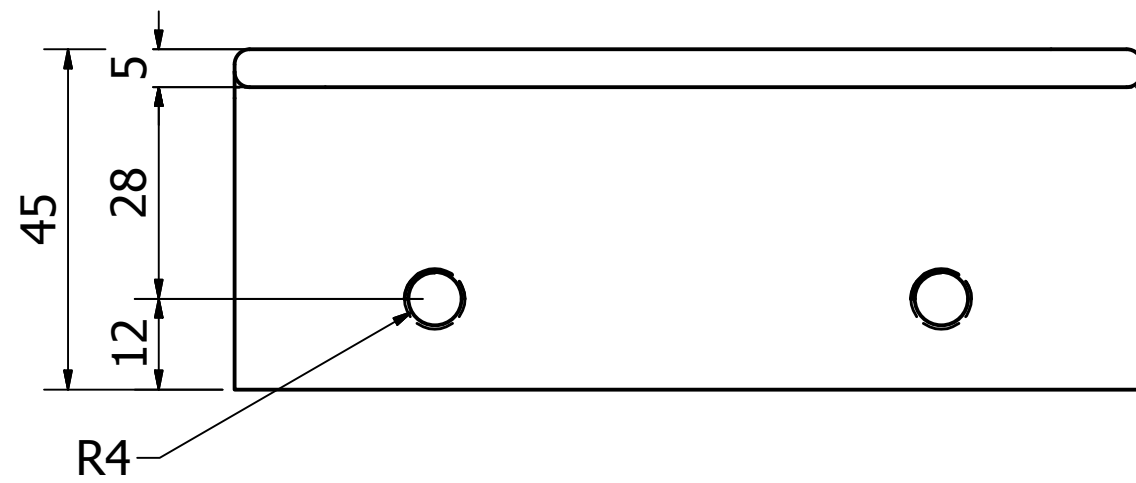

VISTA FRONTAL

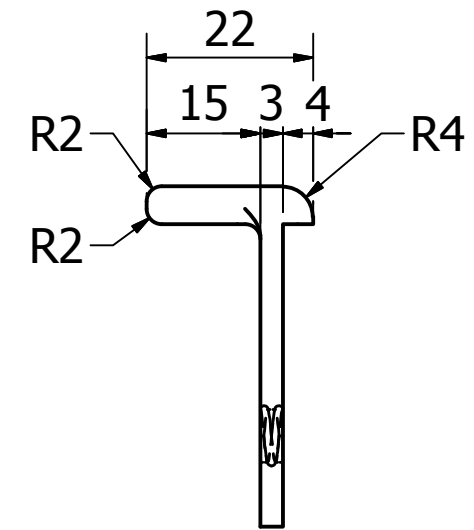

VISTA LATERAL DERECHA

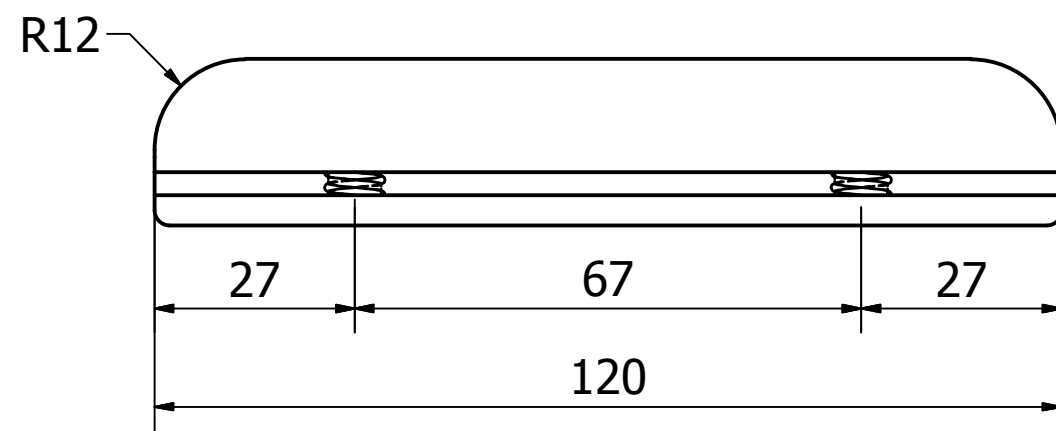

VISTA INFERIOR

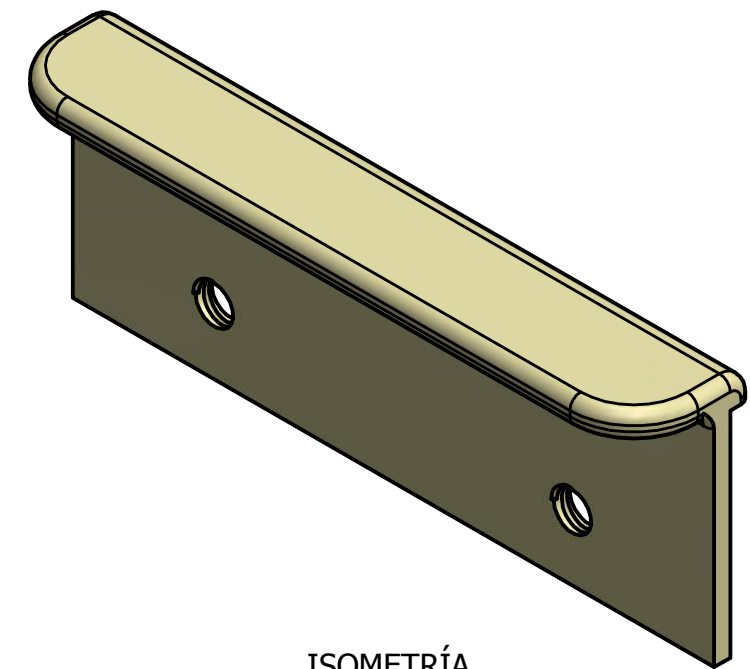

ISOMETRÍA

TRABAJO DE FIN DE CARRERA			
	Carrera de Diseño de Productos		Isaac Díaz
	Contiene 9._ Jaladera		Director D.H
	Medidas en mm	20/09/2017	Escala 1:1
			13 de 19

ISO 7049 - ST 3.5 x 9.5 - C - H

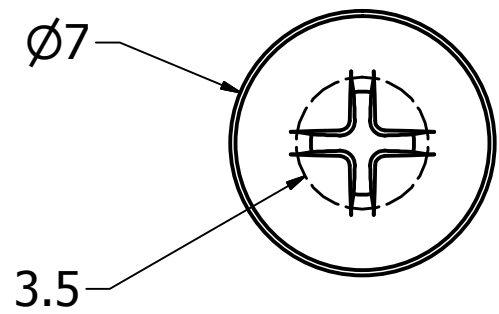

VISTA SUPERIOR

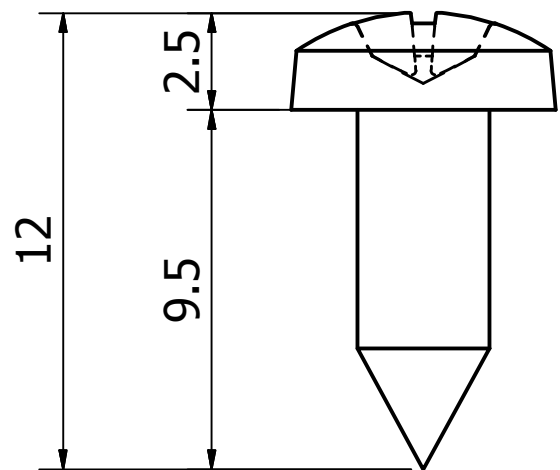

VISTA FRONTAL



ISOMETRIA

ISO 7049 - ST 2,9 x 6,5 - C - Z

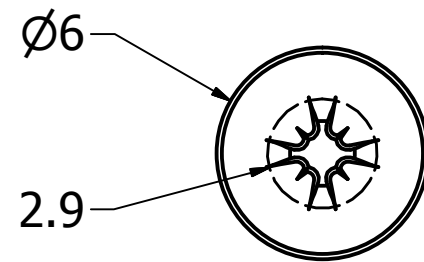

VISTA SUPERIOR

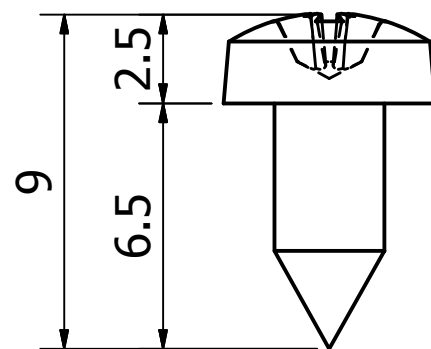

VISTA FRONTAL



ISOMETRIA

ISO 7049 - ST 2,9 x 9,5 - C - Z

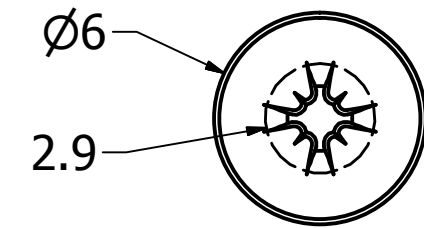

VISTA SUPERIOR

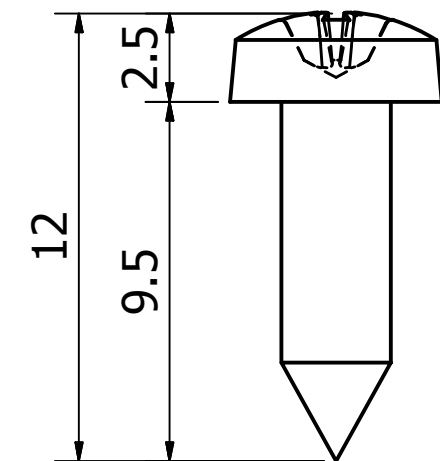

VISTA FRONTAL



ISOMETRIA

TRABAJO DE FIN DE CARRERA



Carrera de Diseño de Productos

Isaac Díaz

Contiene
10,11,12._ Tornillos de cabeza redonda

Director
D.H

14 de 19

Medidas en mm

20/09/2017

Escala
5:1

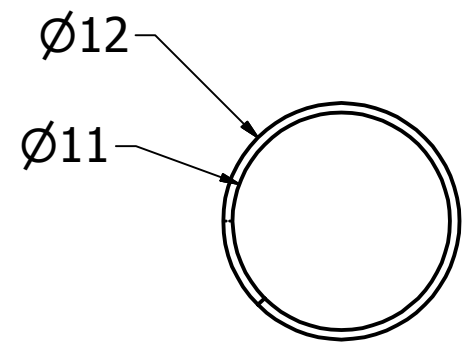

VISTA SUPERIOR

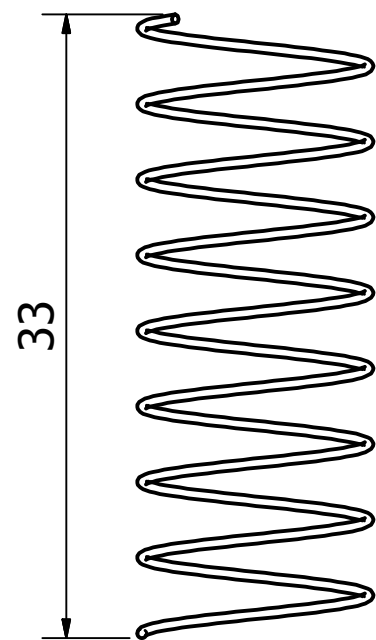

VISTA FRONTAL

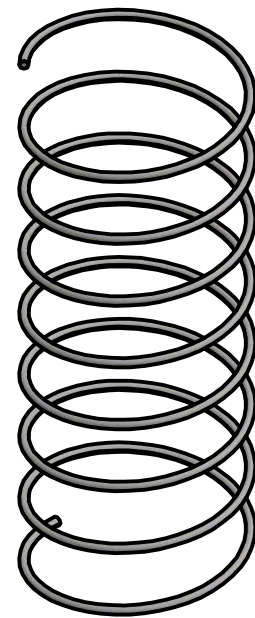

ISOMETRIA

ESCALA 2,5:1

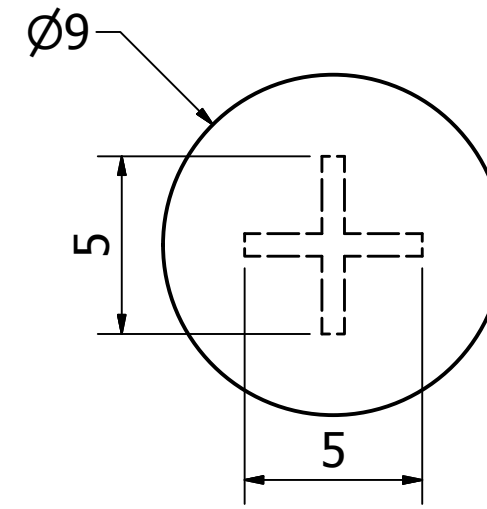

VISTA SUPERIOR

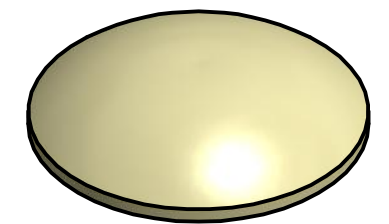

ISOMETRIA

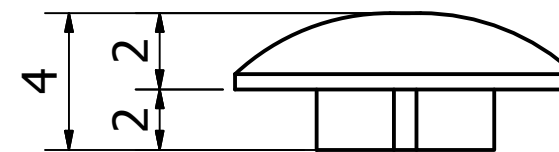

VISTA FRONTAL

ESCALA 5:1

TRABAJO DE FIN DE CARRERA			
	Carrera de Diseño de Productos		Isaac Díaz
	Contiene 13,14._ Resorte y Tapa de tornillo		Director D.H
	Medidas en mm	20/09/2017	Escala Varios
			15 de 19

ISO 7046-1 - M4 x 10 - 4.8 - HISO

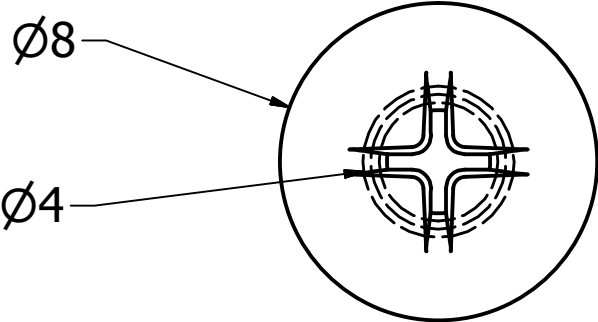

VISTA SUPERIOR

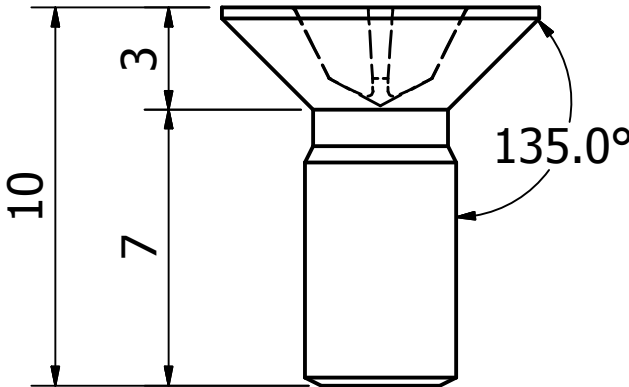

VISTA FRONTAL

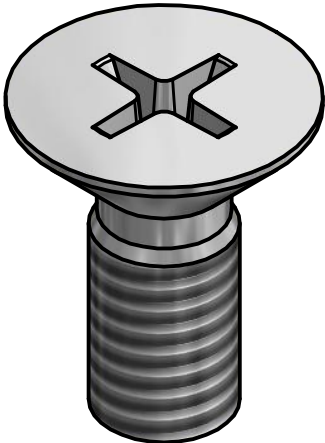

ISOMETRIA

ISO 10642 - M6 x 10

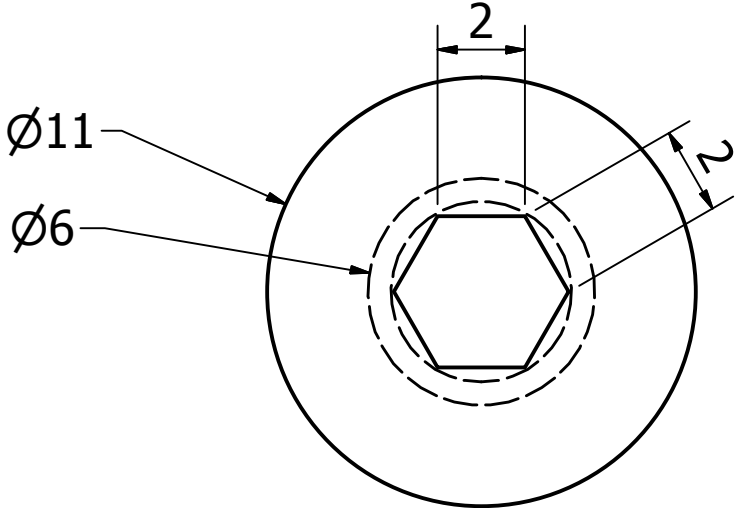

VISTA SUPERIOR

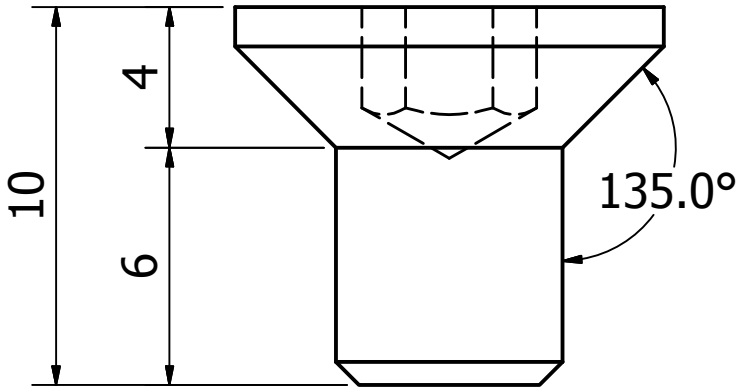

VISTA FRONTAL

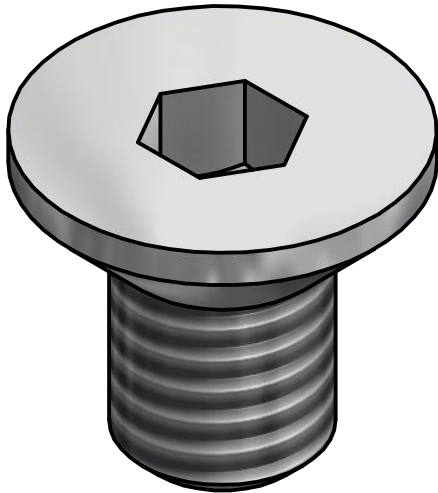

ISOMETRIA

TRABAJO DE FIN DE CARRERA			
	Carrera de Diseño de Productos		Isaac Díaz
	Contiene 15,16._ Tornillos de cabeza avellanada		Director D.H
	Medidas en mm	20/09/2017	Escala 5:1
			16 de 19

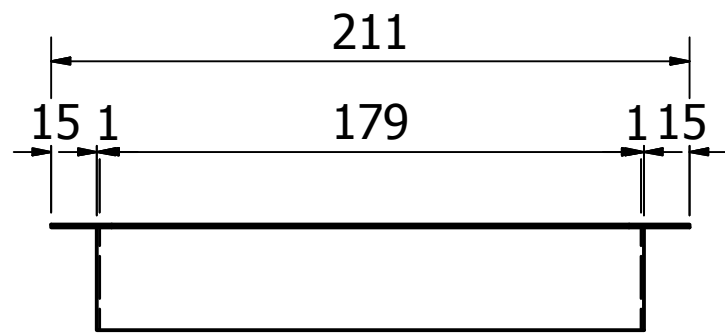

VISTA FRONTAL

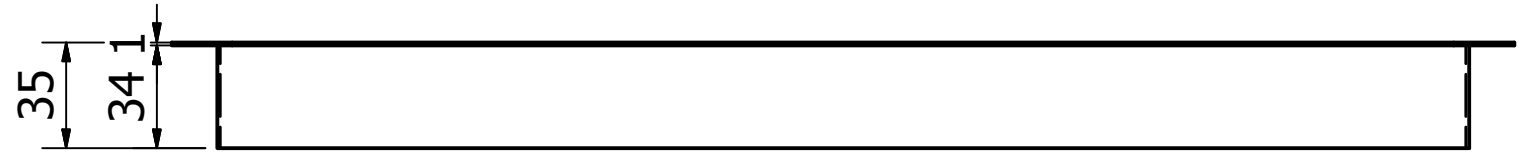

VISTA LATERAL DERECHA

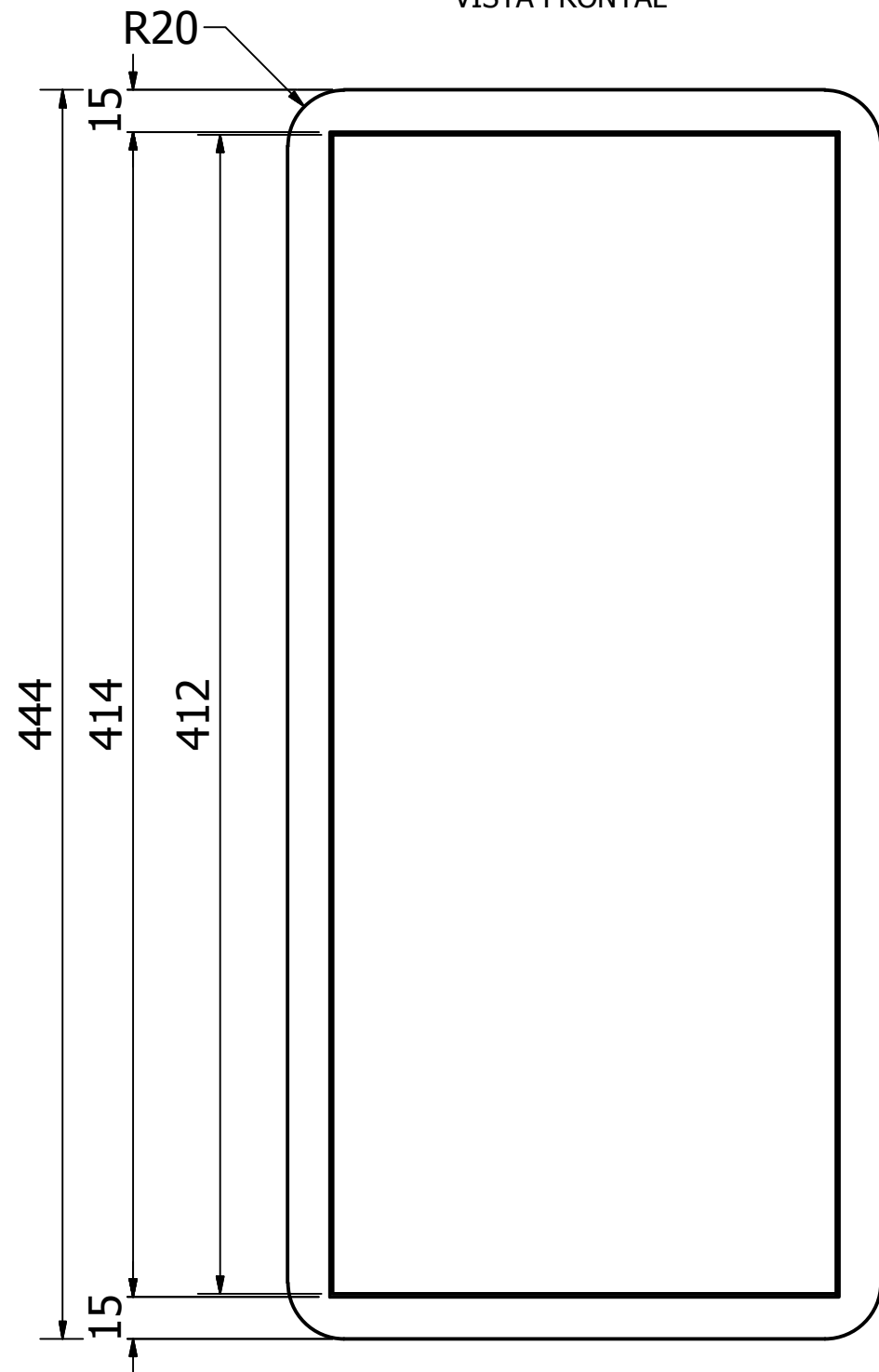

VISTA INFERIOR

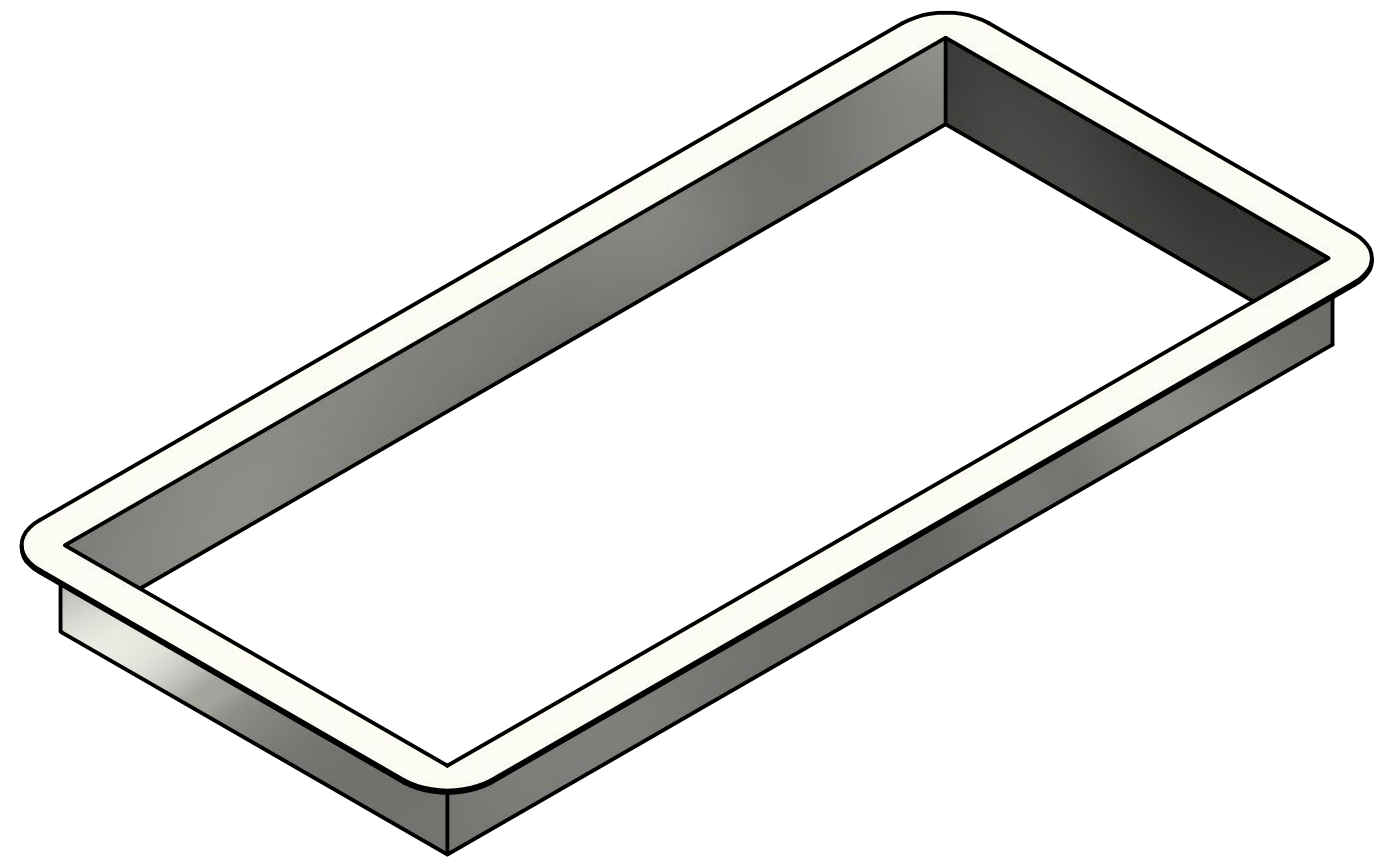

ISOMETRÍA

TRABAJO DE FIN DE CARRERA			
	Carrera de Diseño de Productos		Isaac Díaz
	Contiene	17._ Bastidor	Director D.H
	Medidas en mm	20/09/2017	Escala 1:2,5
			17 de 19

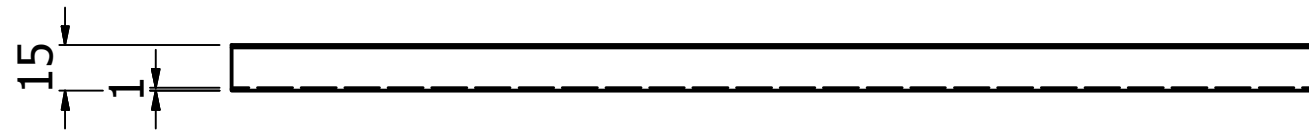

VISTA SUPERIOR

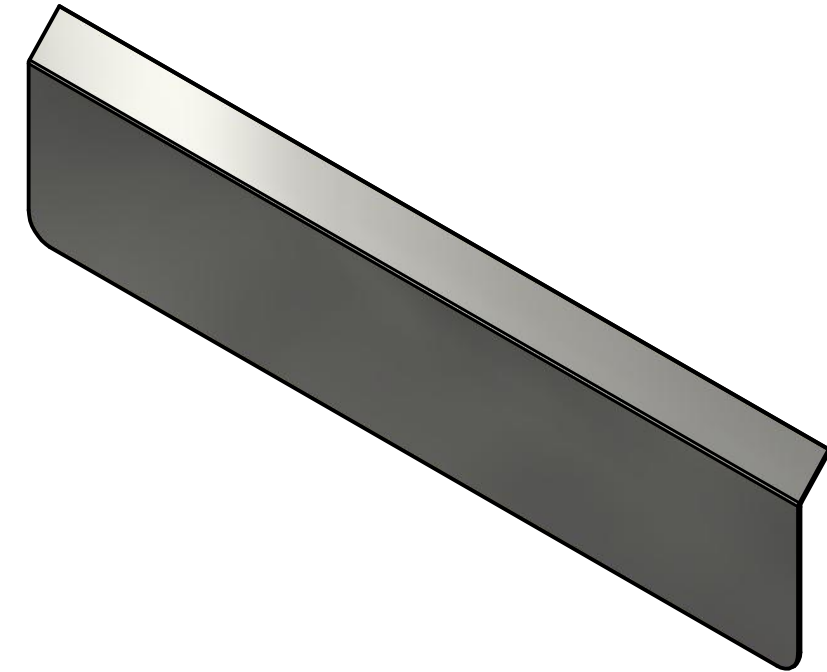

ISOMETRIA

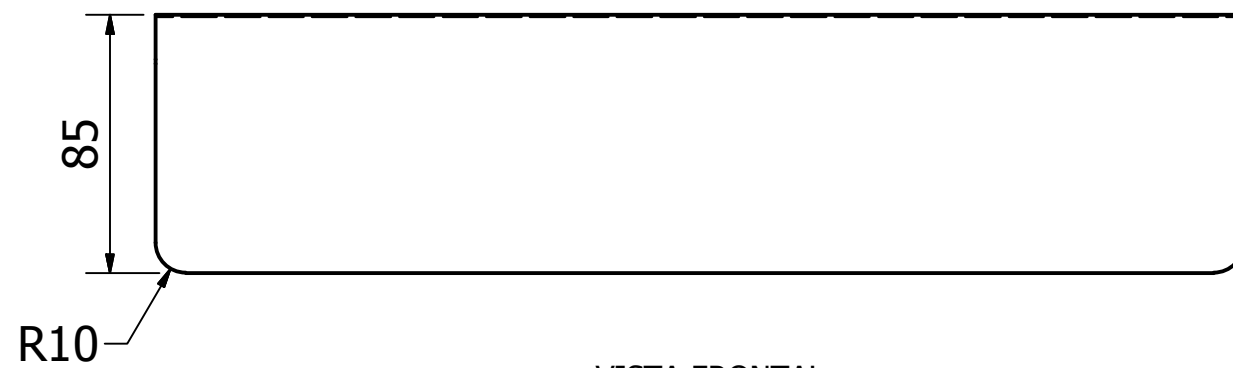

VISTA FRONTAL

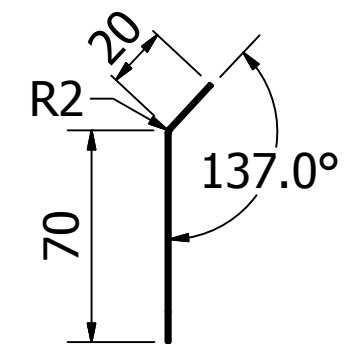

VISTA LATERAL DERECHA

TRABAJO DE FIN DE CARRERA			
	Carrera de Diseño de Productos		Isaac Díaz
	Contiene 18._ Separador de masa		Director D.H
	Medidas en mm	20/09/2017	Escala 1:2,5
			18 de 19

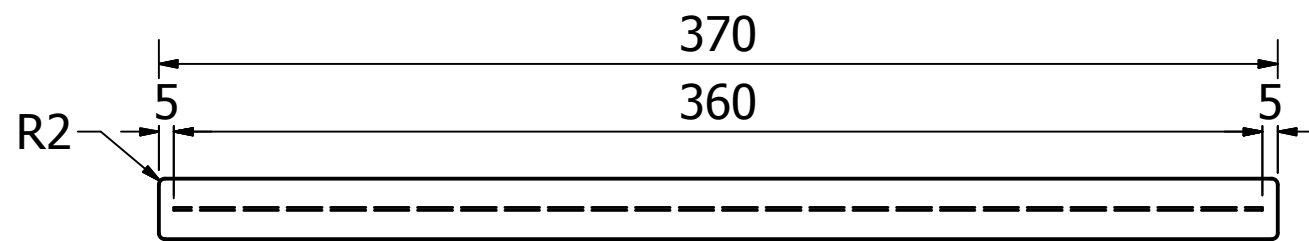

VISTA SUPERIOR

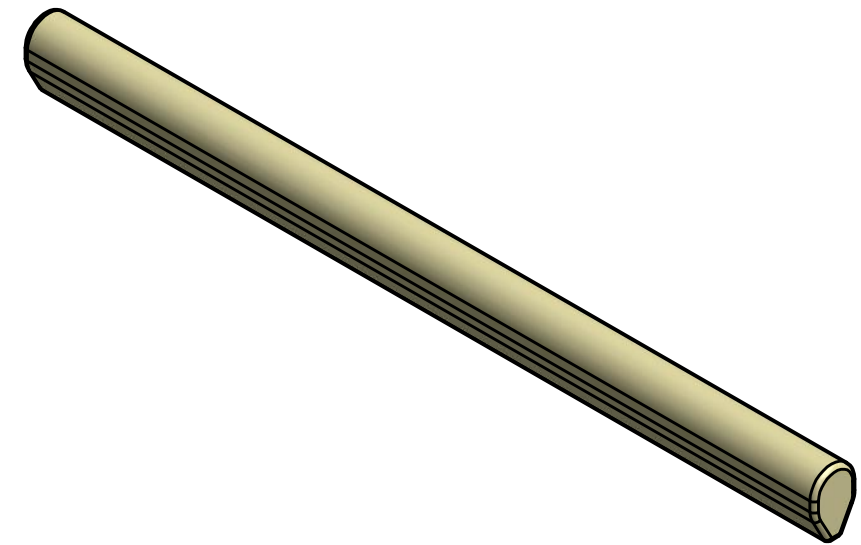

ISOMETRÍA

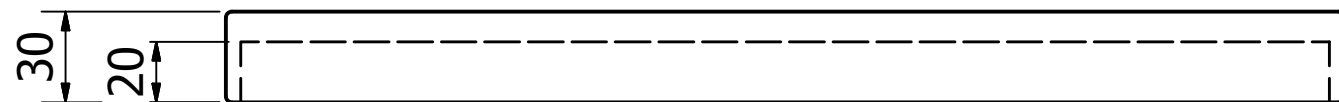

VISTA FRONTAL

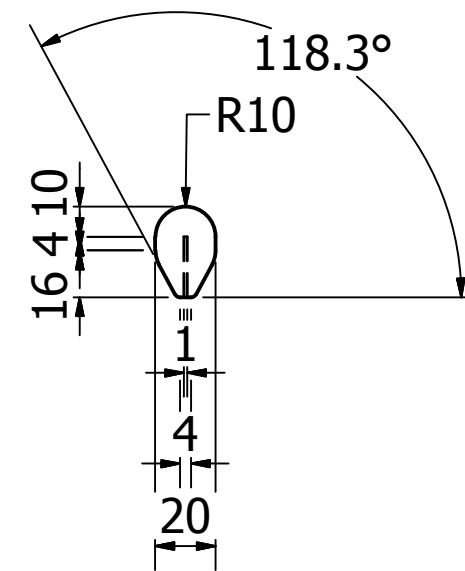

VISTA LATERAL DERECHA

TRABAJO DE FIN DE CARRERA			
	Carrera de Diseño de Productos		Isaac Díaz
	Contiene 19._ Soporte de agarre del separador		Director D.H
	Medidas en mm	20/09/2017	Escala 1:2,5
			19 de 19