





Pontificia Universidad Católica del Ecuador			Contiene: 1 de 14
Diseño de Productos			Formato: A3
	Contiene: Vistas Generales		
Dibujado por: Priscila Aguinaga H.	Medida en mm	Fecha: Enero, 2019	Escala: 1:20



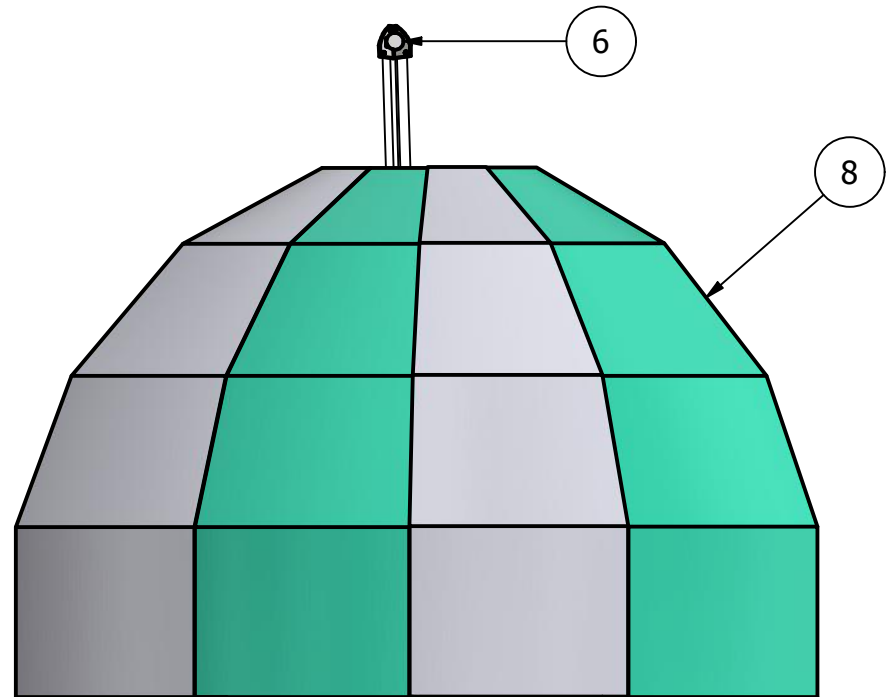
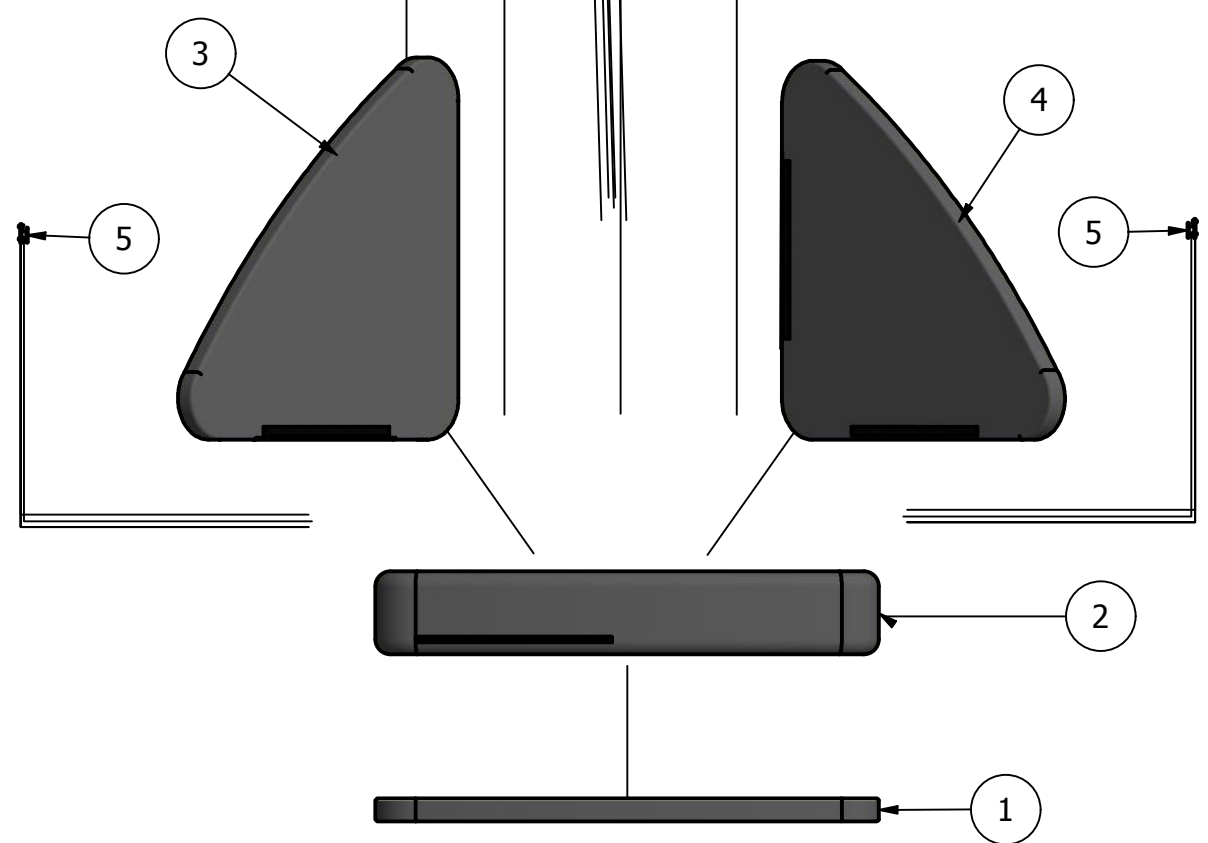

LISTA DE PIEZAS			
ELEMENTO	CTDAD	Nº DE PIEZA	MATERIAL
1	1	Respaldo piso	Felpa Dofaz, expandible cielo, cierre, velcro, esponja negra
2	1	Cojín	Felpa Dofaz, expandible cielo, cierre, velcro, bramante, plumón
3	1	Respaldo izquierdo	Felpa Dofaz, expandible cielo, cierre, velcro, esponja
4	1	Respaldo derecho	Felpa Dofaz, expandible cielo, cierre, velcro, esponja
5	2	Accesorio pared	Plástico ABS
6	1	Accesorio esquina	Plástico ABS
7	10	Tornillos	Acero, suave
8	1	Estructura	Pelón, Tricot sin respaldo, arabella blanca y verde agua



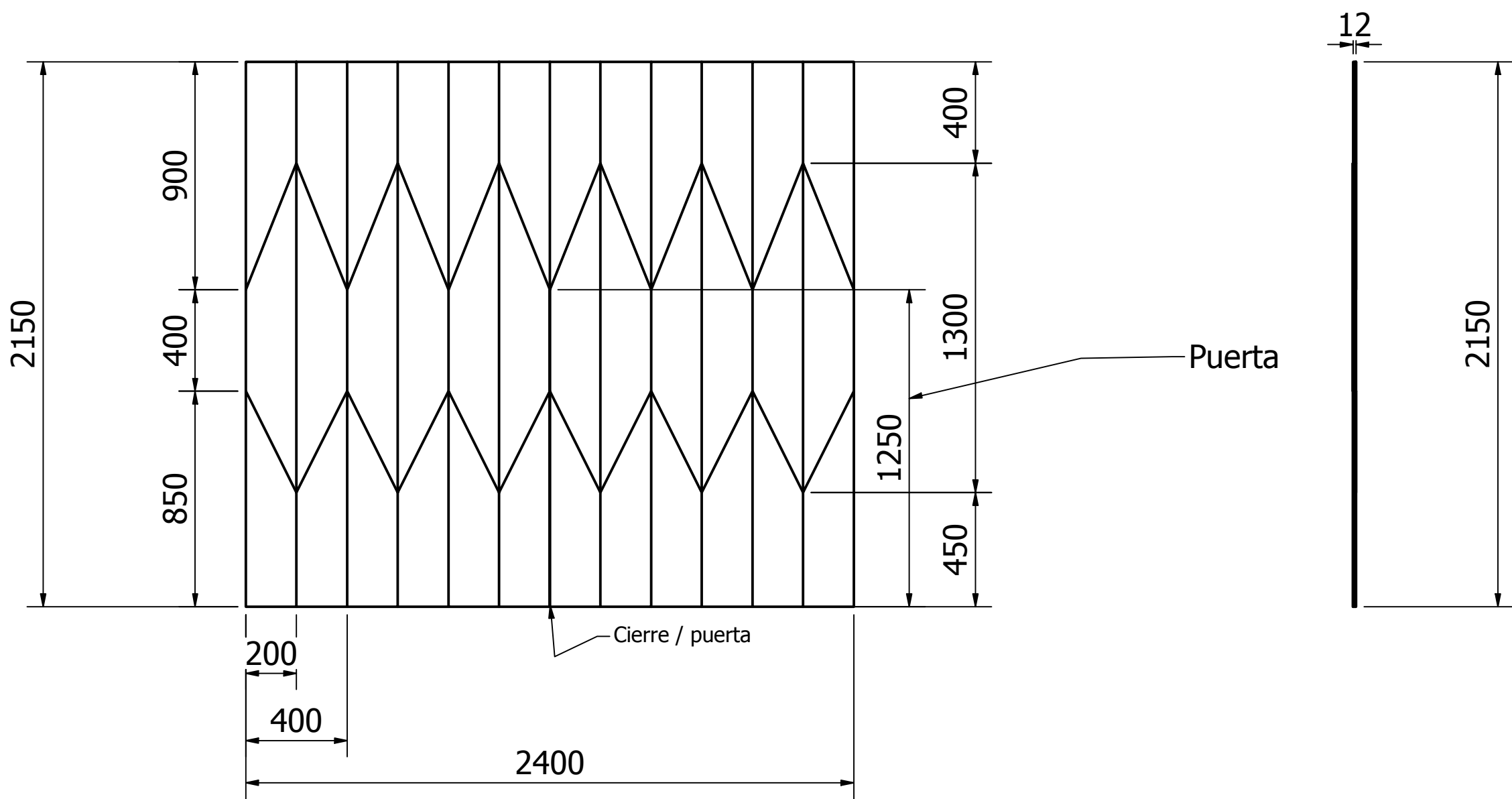

Pontificia Universidad Católica del Ecuador			Contiene: 2 de 14
Diseño de Productos			Formato: A3
	Contiene: Despiece / lista de materiales		
Dibujado por: Priscila Aguinaga H.	Medida en mm	Fecha: Enero, 2019	Escala: 1:20

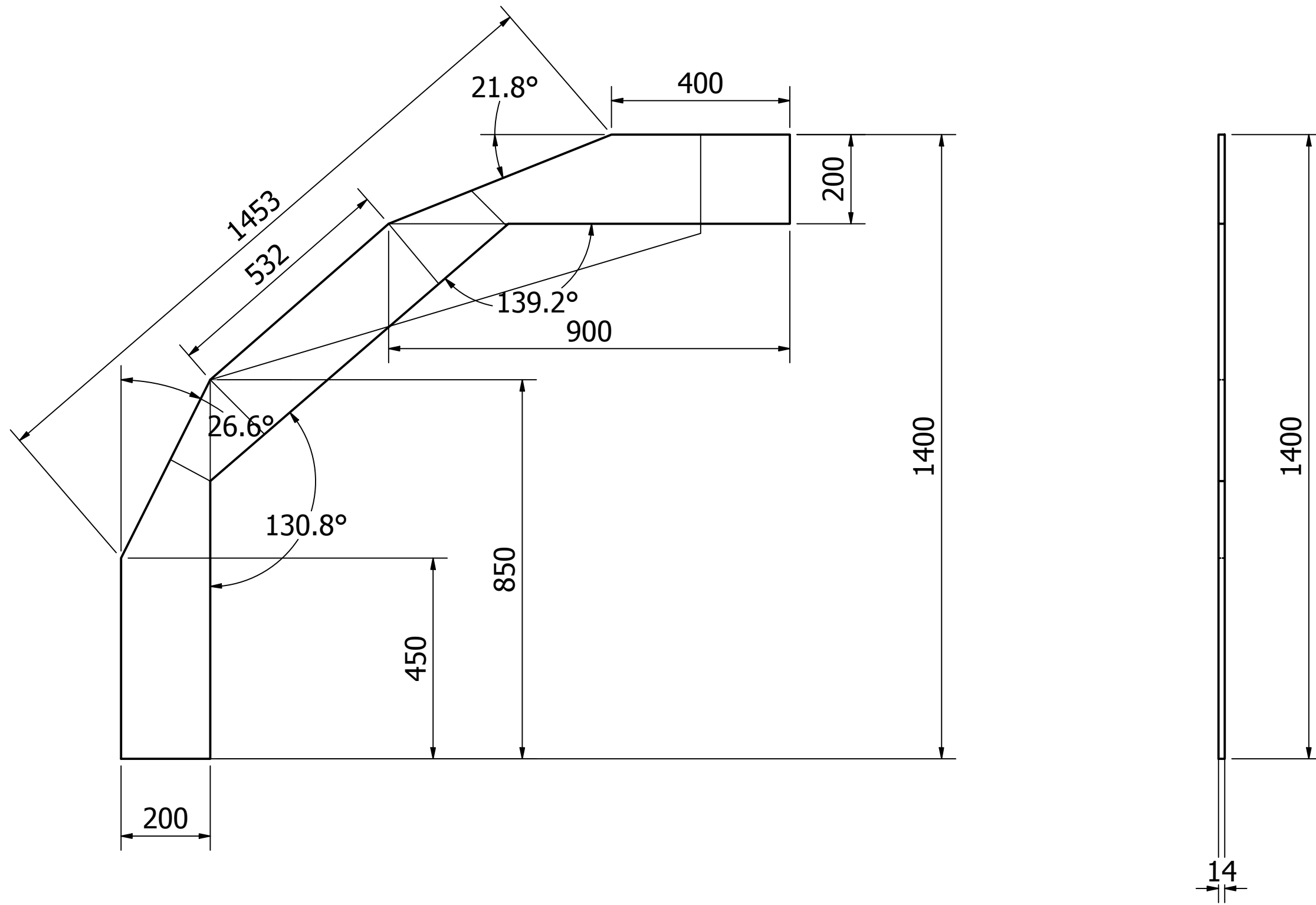

Pontificia Universidad Católica del Ecuador			Contiene: 3 de 14
Diseño de Productos			Formato: A3
	Contiene: Medidas estructura extendida		
Dibujado por: Priscila Aguinaga H.	Medida en mm	Fecha: Enero, 2019	Escala: 1:20



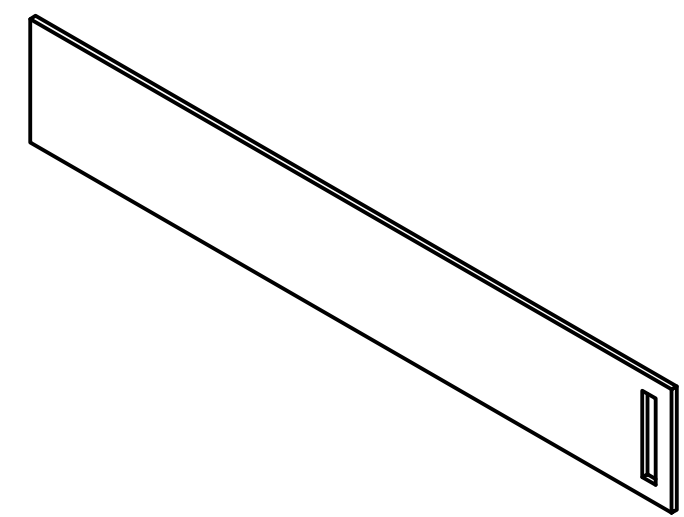
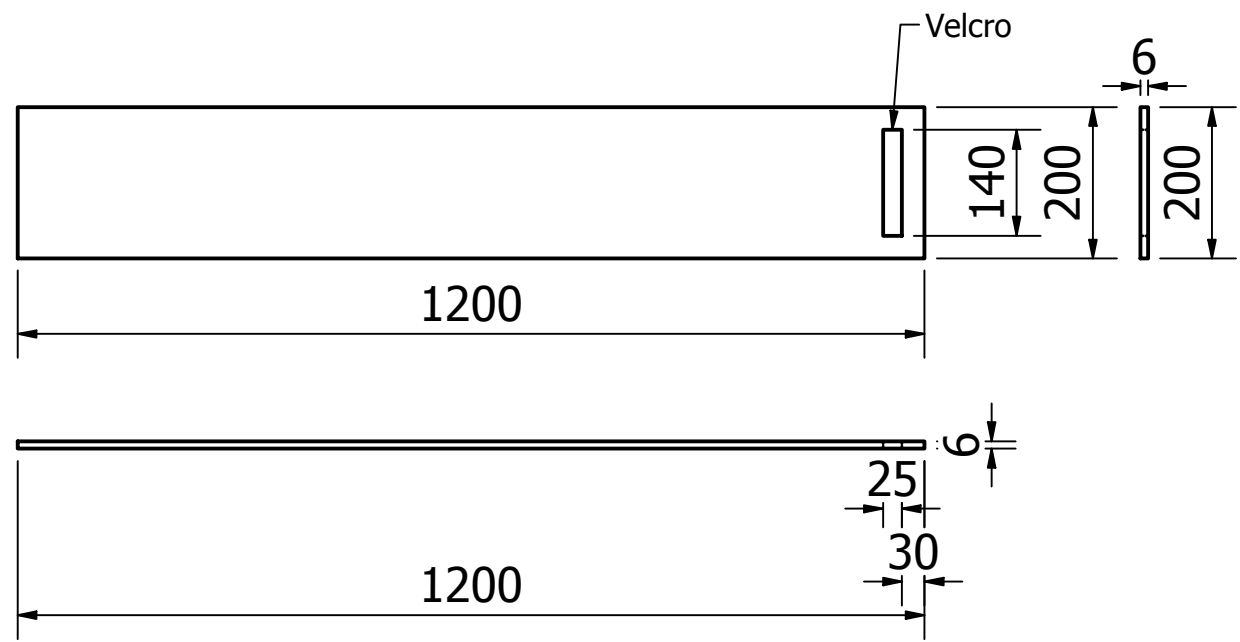

Pontificia Universidad Católica del Ecuador			Contiene: 4 de 14
Diseño de Productos			Formato: A3
	Contiene: Esquema de plegabilidad		
Dibujado por: Priscila Aguinaga H.	Medida en mm	Fecha: Enero, 2019	Escala: 1:10



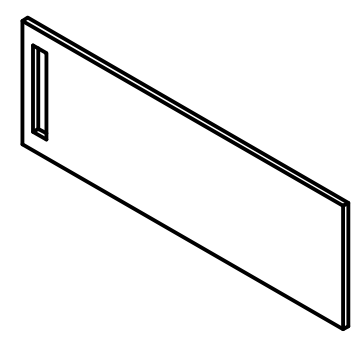
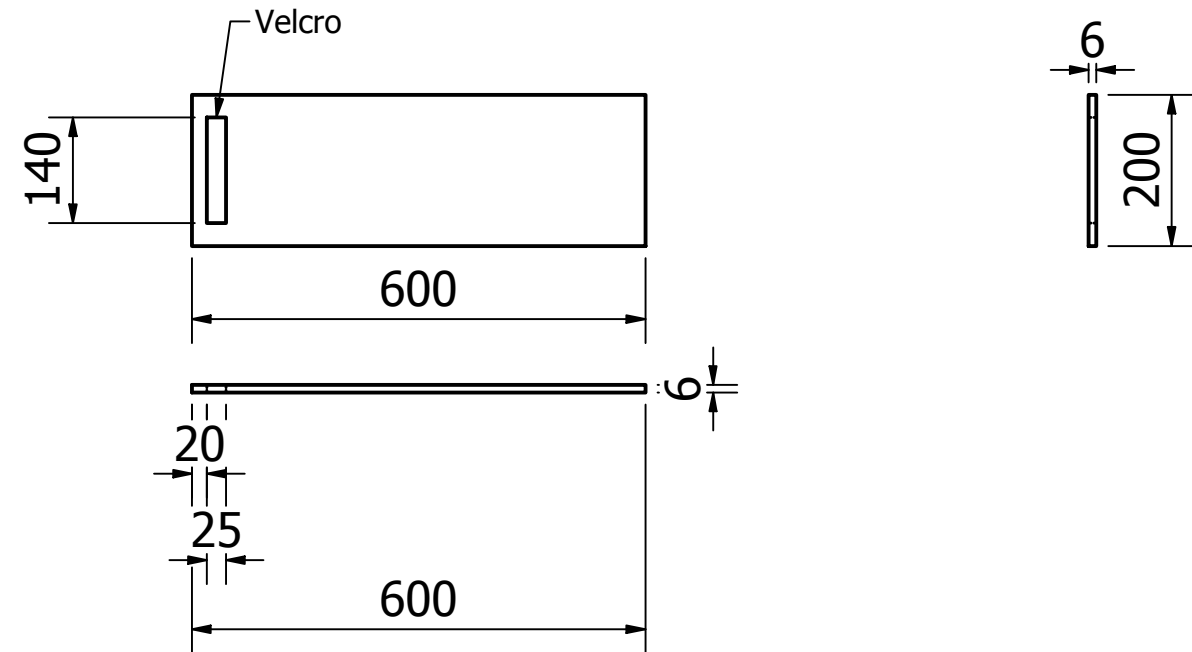

Tira plegabilidad



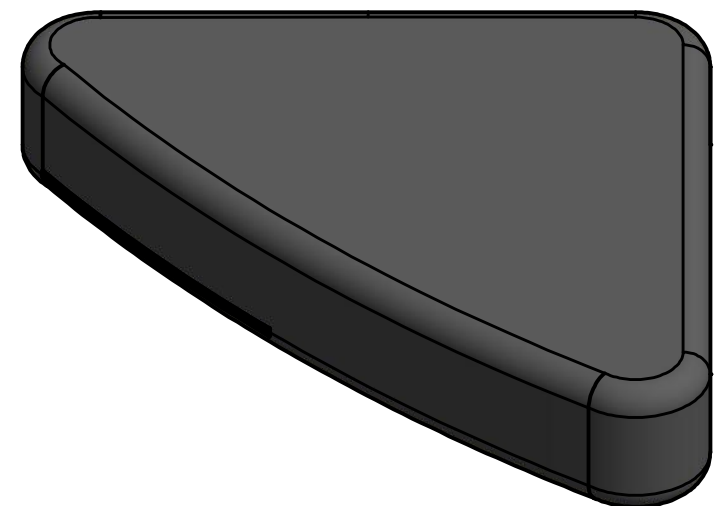
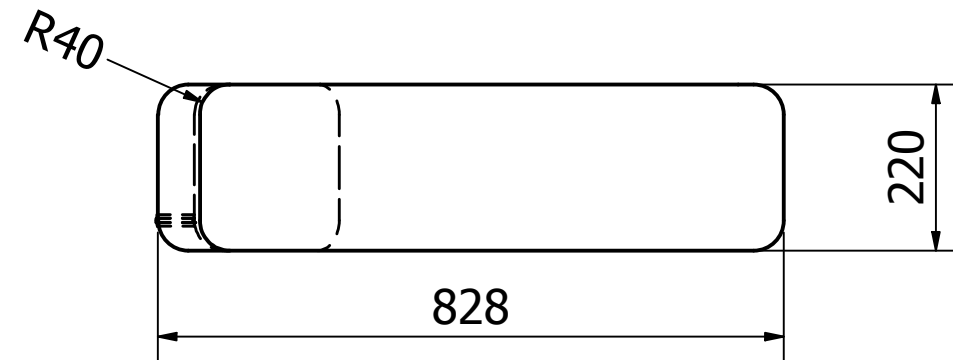
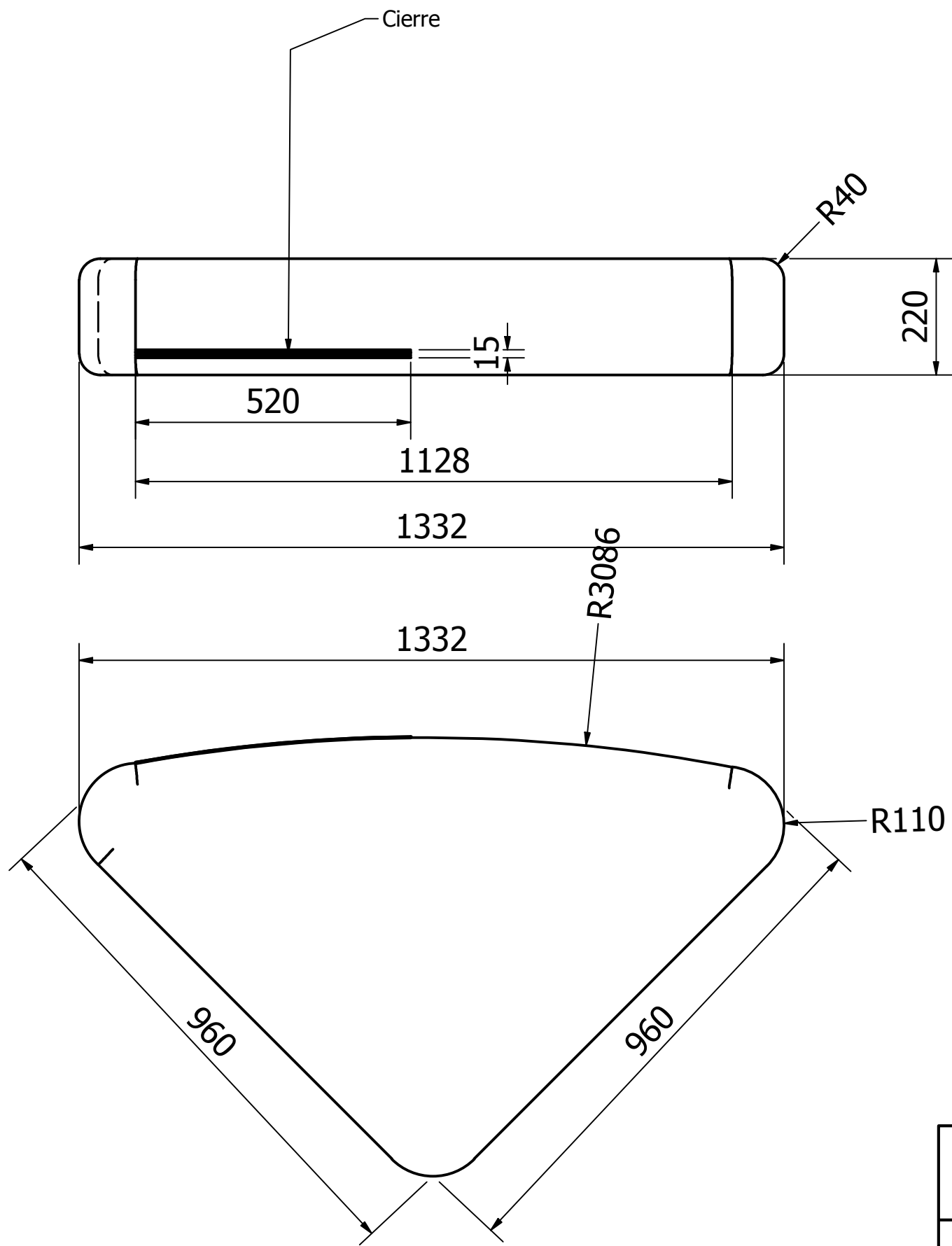

Tira soporte superior

Pontificia Universidad Católica del Ecuador			Contiene: 5 de 14
Diseño de Productos			Formato: A3
	Contiene: Tiras de soporte estructura		
Dibujado por: Priscila Aguinaga H.	Medida en mm	Fecha: Enero, 2019	Escala: 1:10



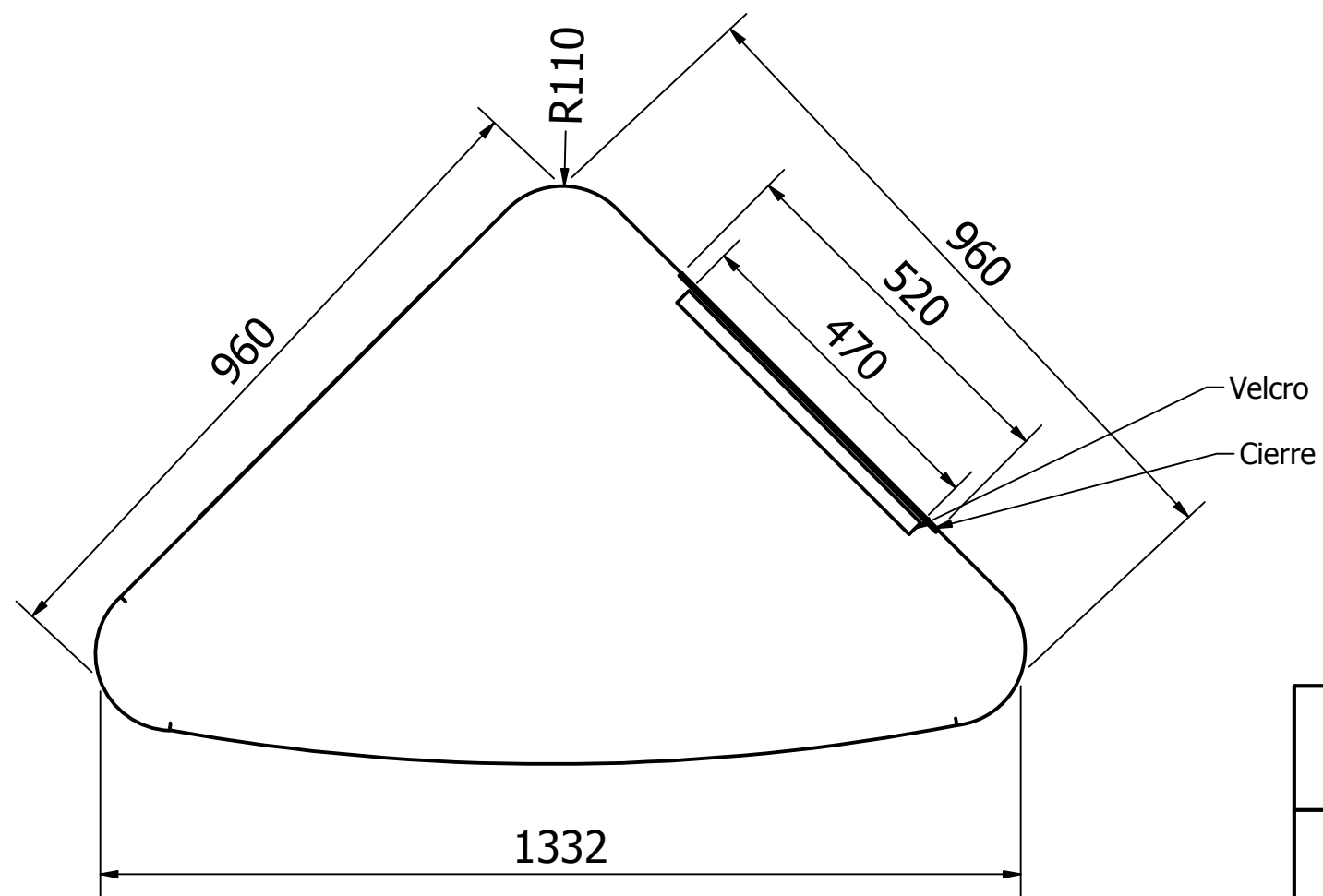
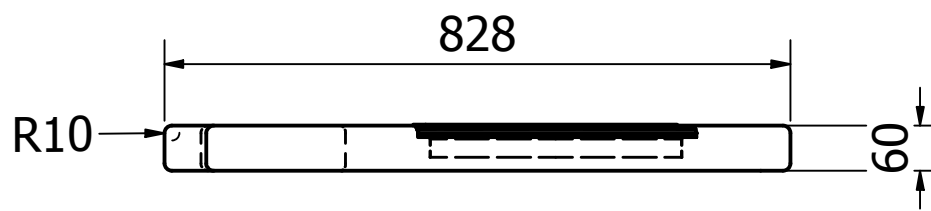
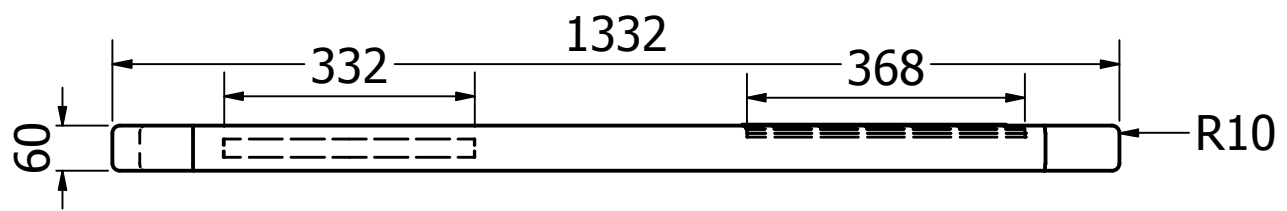

Pontificia Universidad Católica del Ecuador			Contiene: 6 de 14
Diseño de Productos			Formato: A3
	Contiene: Cojín		
Dibujado por: Priscila Aguinaga H.	Medida en mm	Fecha: Enero, 2019	Escala: 1:20

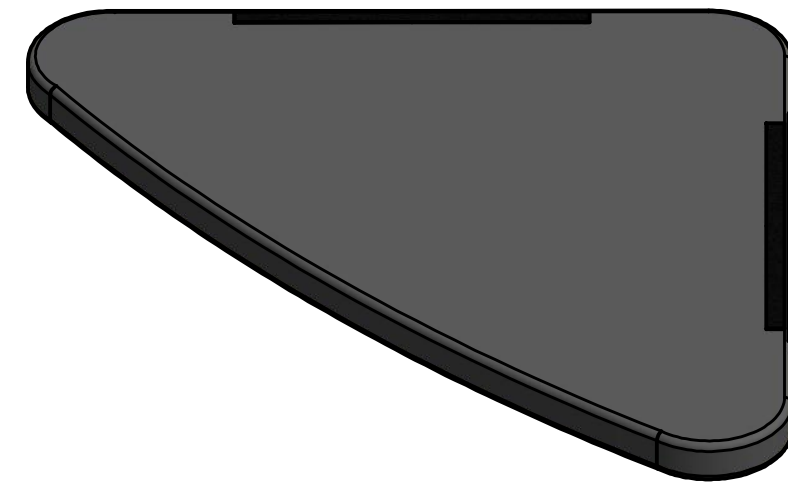
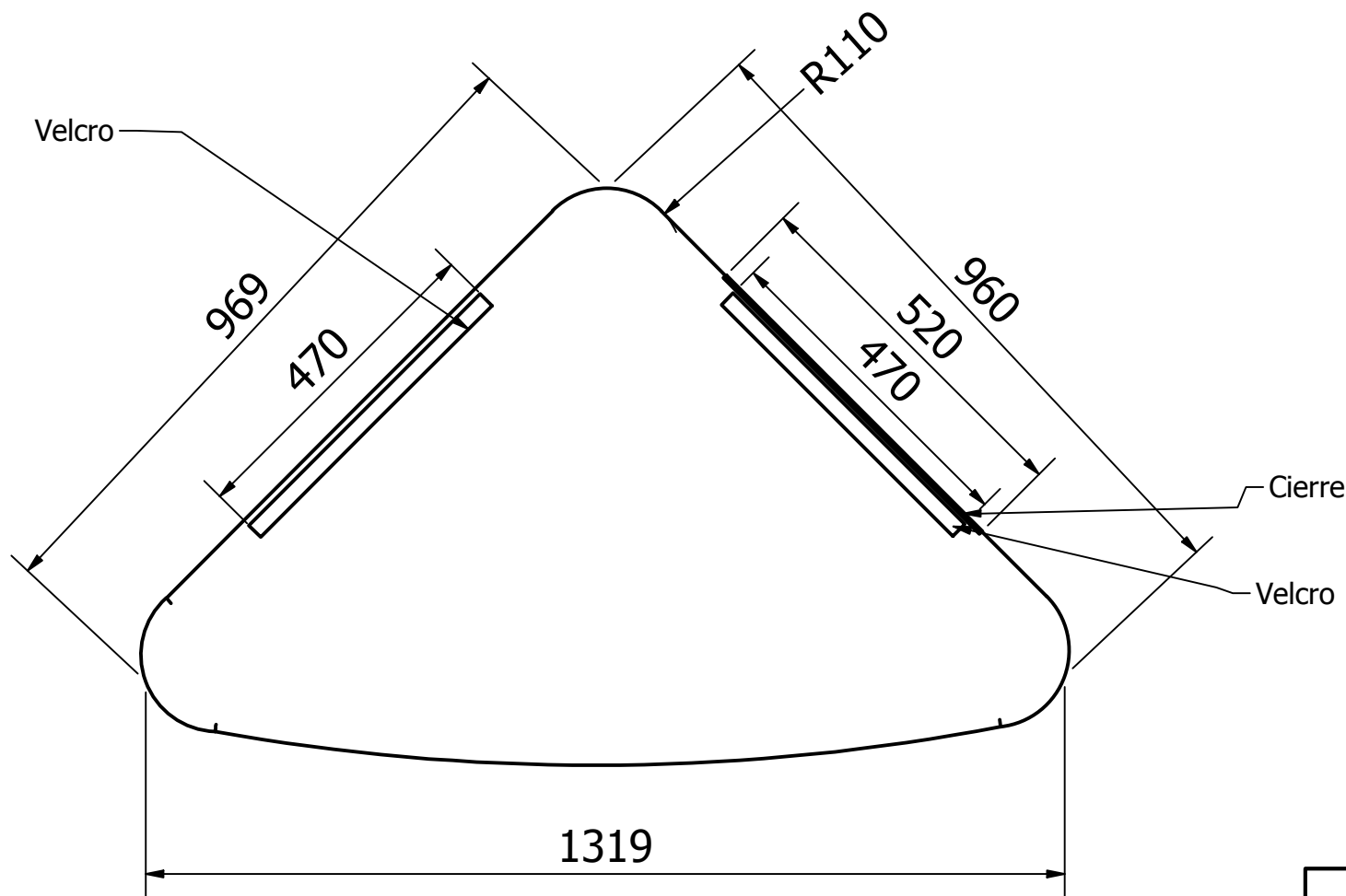
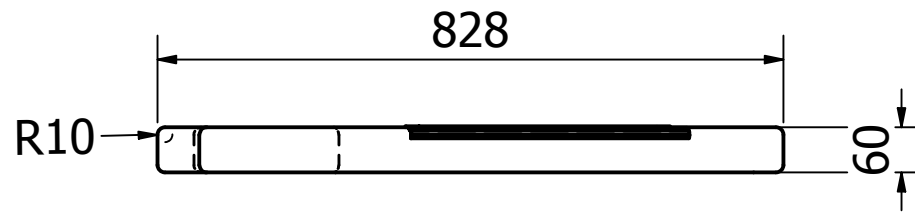
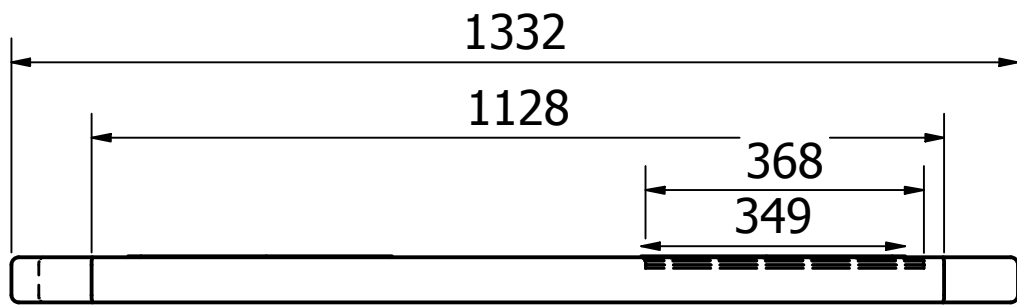

Pontificia Universidad Católica del Ecuador			Contiene: 7 de 14
Diseño de Productos			Formato: A3
	Contiene: Respaldo izquierdo		
Dibujado por: Priscila Aguinaga H.	Medida en mm	Fecha: Enero, 2019	Escala: 1:10



Pontificia Universidad Católica del Ecuador			Contiene: 8 de 14
Diseño de Productos			Formato: A3
	Contiene: Respaldo derecho		
Dibujado por: Priscila Aguinaga H.	Medida en mm	Fecha: Enero, 2019	Escala: 1:10

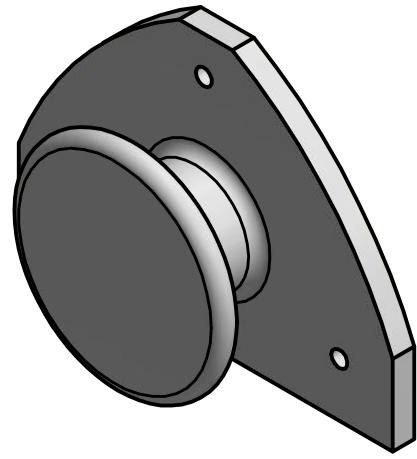
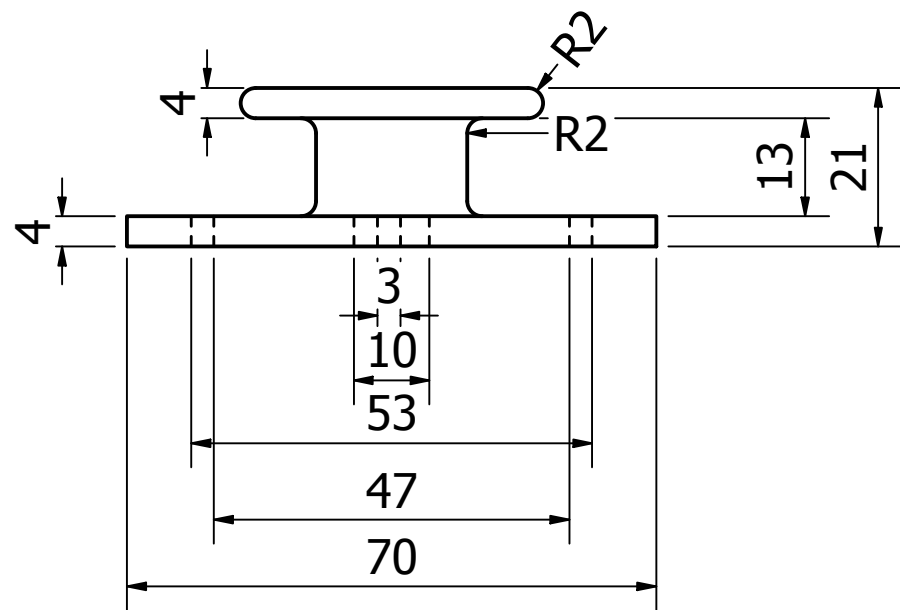
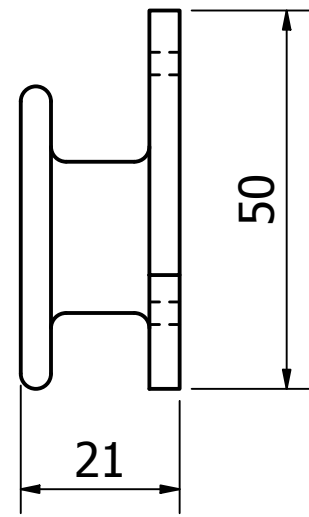
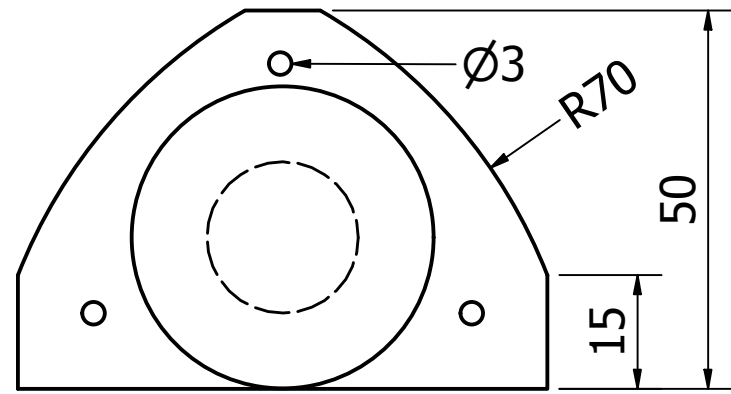

esc. 1:1

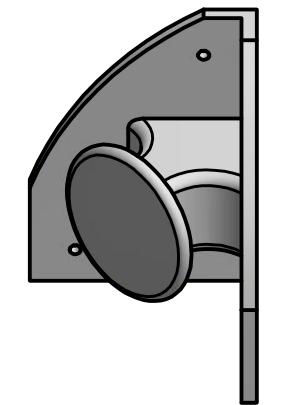
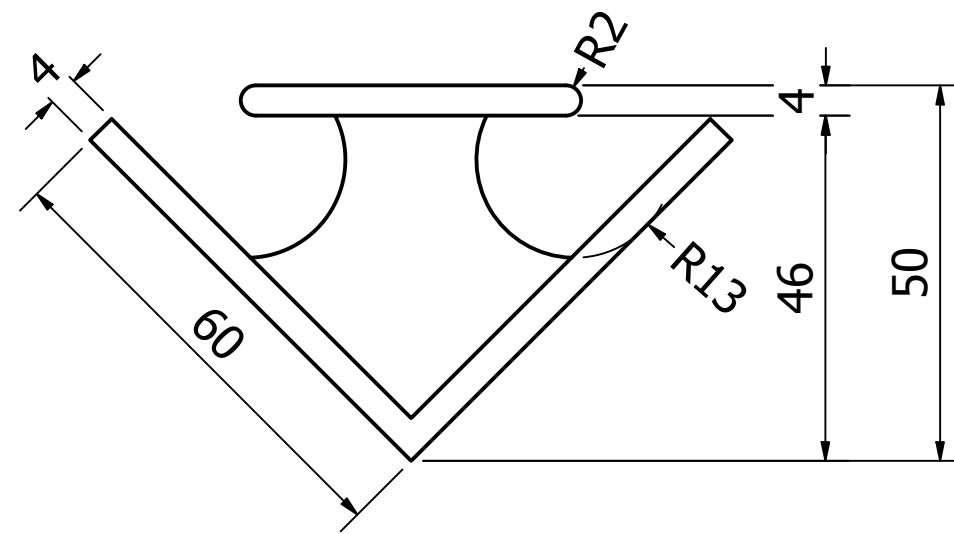
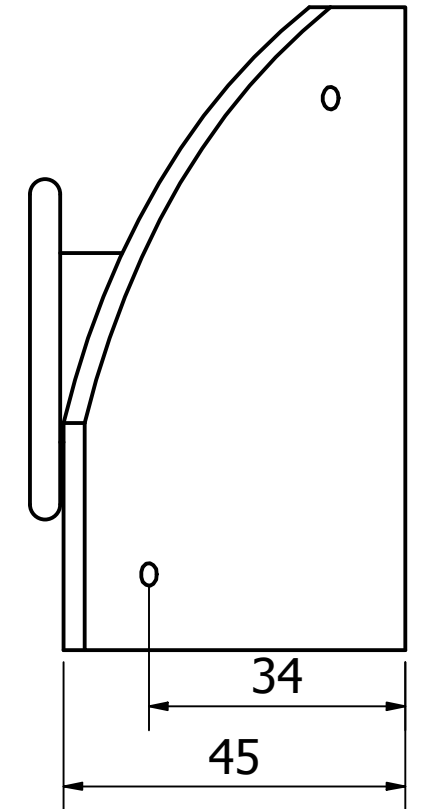
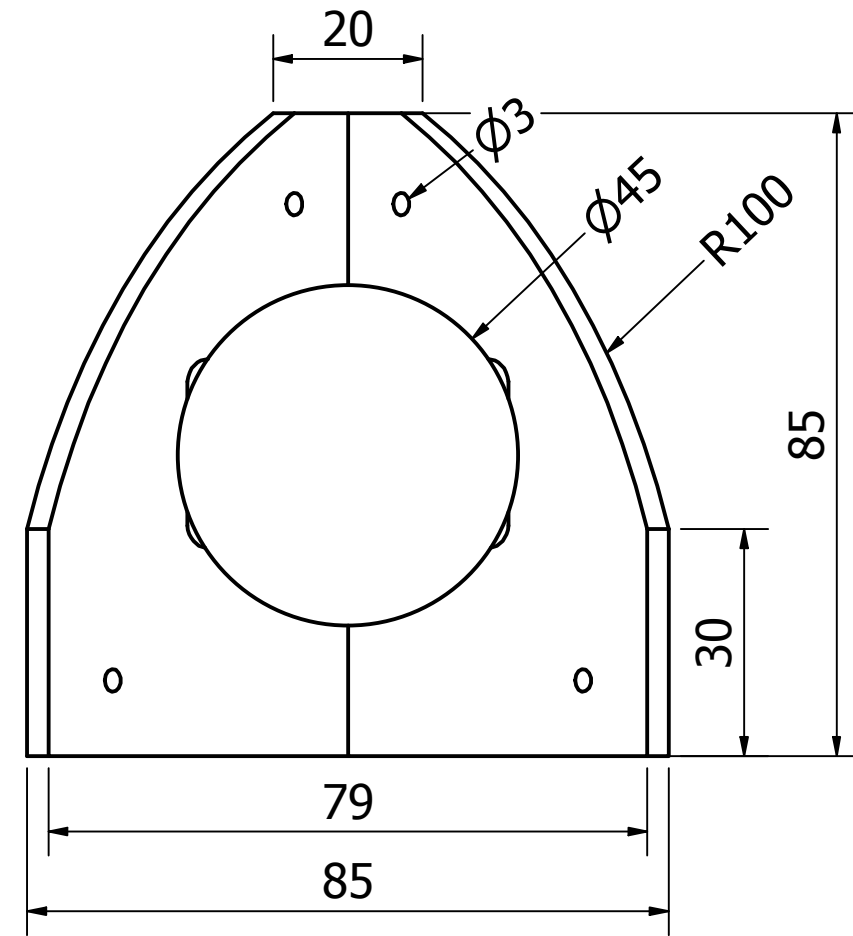

esc. 1:1

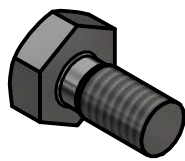
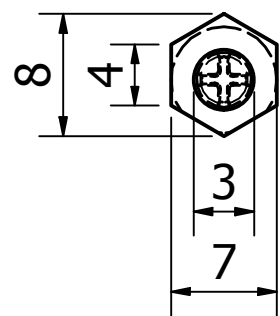
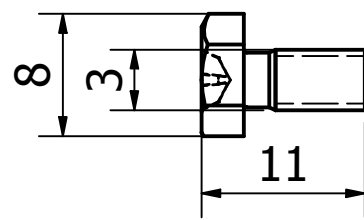

esc. 2:1

Tornillo

Pontificia Universidad Católica del Ecuador

Diseño de Productos



Contiene:  
Accesorios

Dibujado por:  
Priscila Aguinaga H.

Medida en mm

Fecha:  
Enero, 2019

Escala:  
n/a





PUCE

Contiene:  
9 de 14

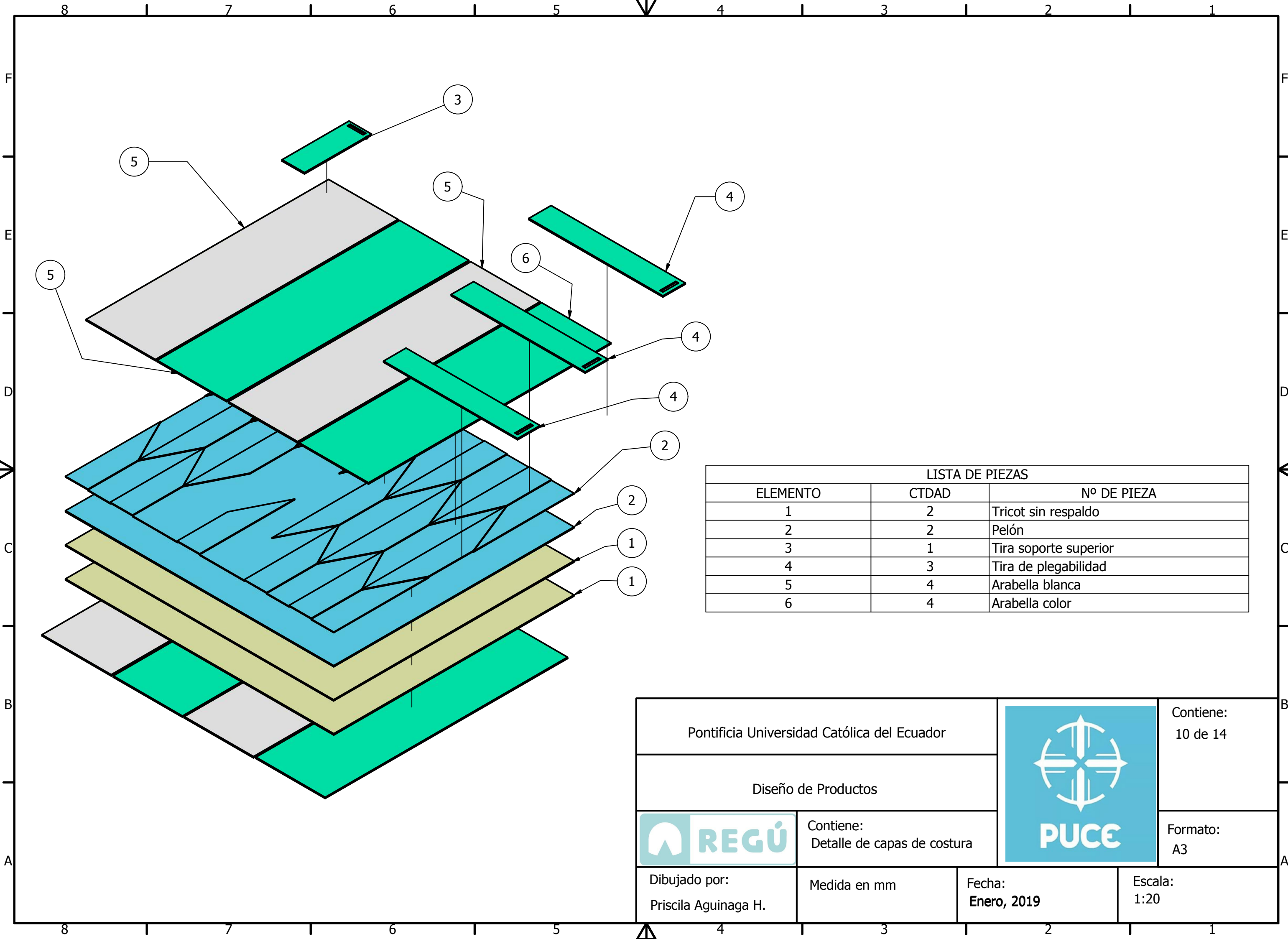

Formato:  
A3

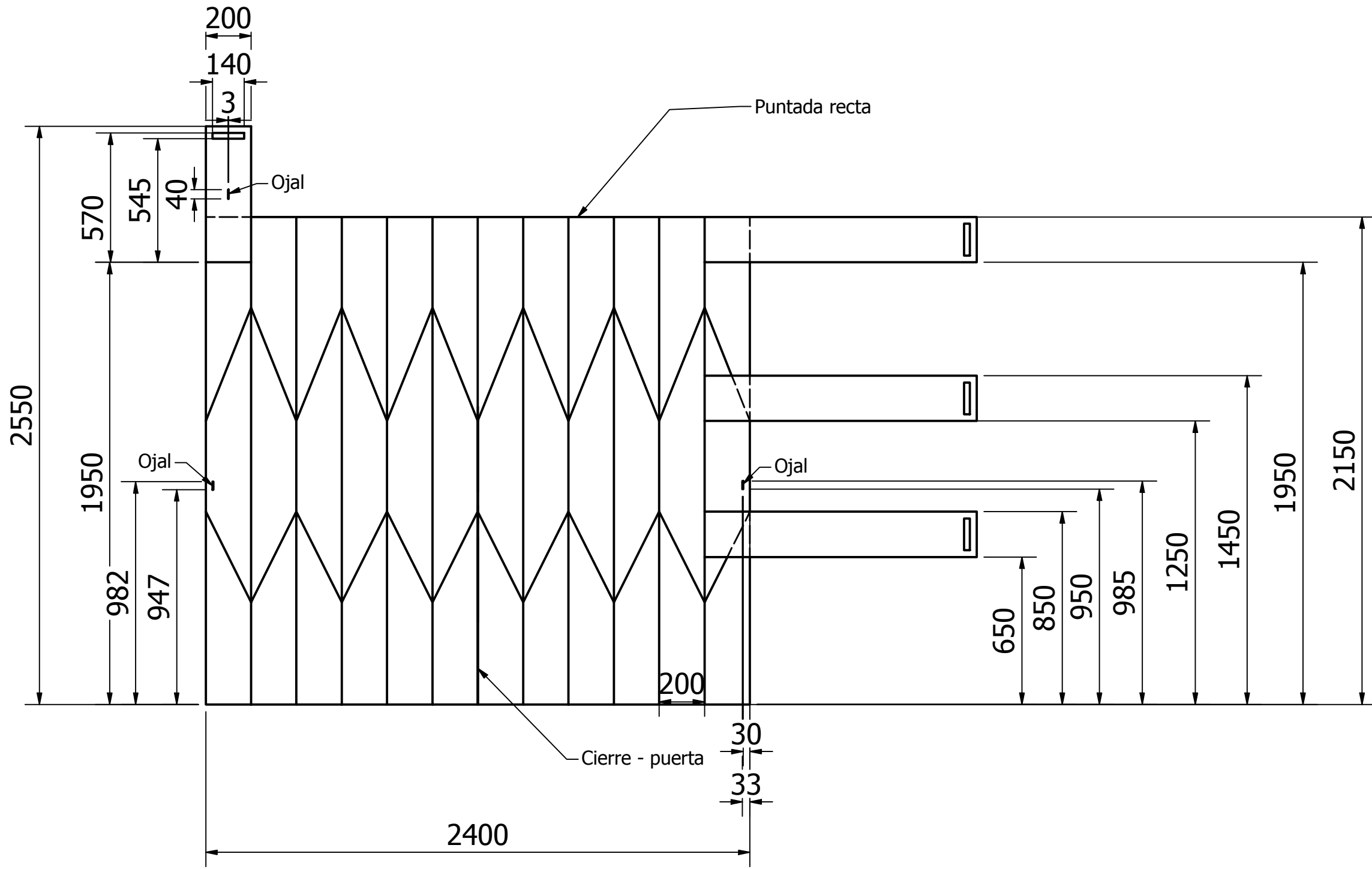

LISTA DE PIEZAS		
ELEMENTO	CTDAD	Nº DE PIEZA
1	2	Tricot sin respaldo
2	2	Pelón
3	1	Tira soporte superior
4	3	Tira de plegabilidad
5	4	Arabella blanca
6	4	Arabella color

Pontificia Universidad Católica del Ecuador			Contiene: 10 de 14
Diseño de Productos			Formato: A3
	Contiene: Detalle de capas de costura		
Dibujado por: Priscila Aguinaga H.	Medida en mm	Fecha: Enero, 2019	Escala: 1:20



Pontificia Universidad Católica del Ecuador			Contiene: 11 de 14
Diseño de Productos			Formato: A3
	Contiene: Acabados		
Dibujado por: Priscila Aguinaga H.	Medida en mm	Fecha: Enero, 2019	Escala: 1:20

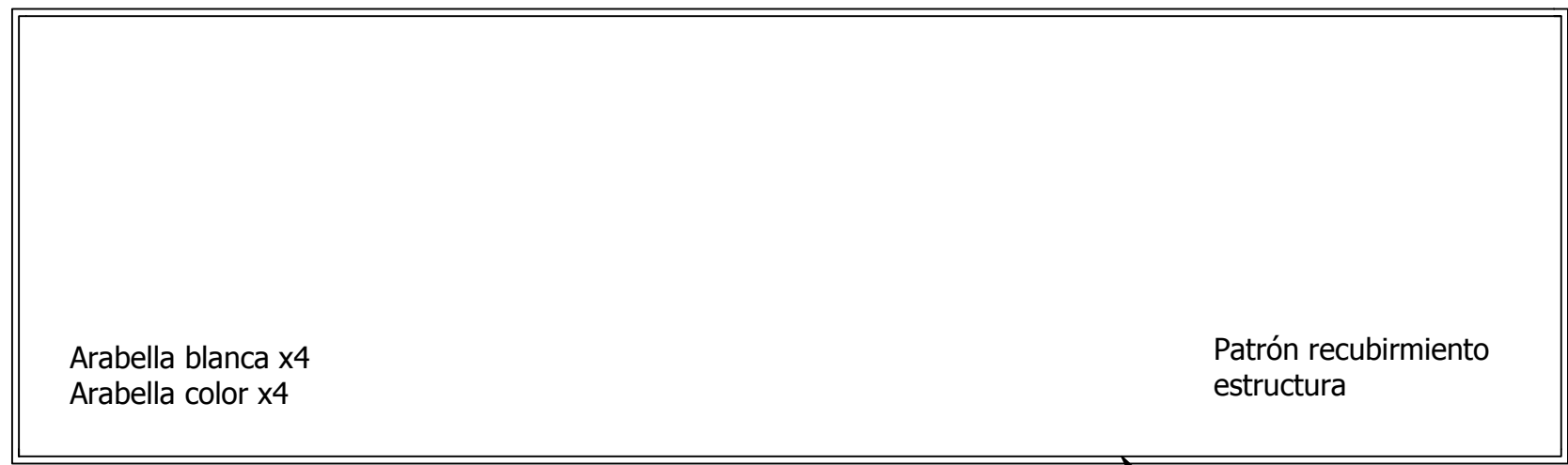

esc. 1:10

Costura recta

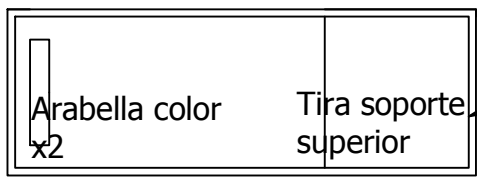

esc. 1:10

Costura recta

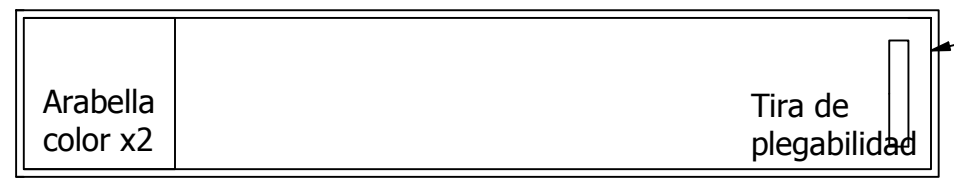

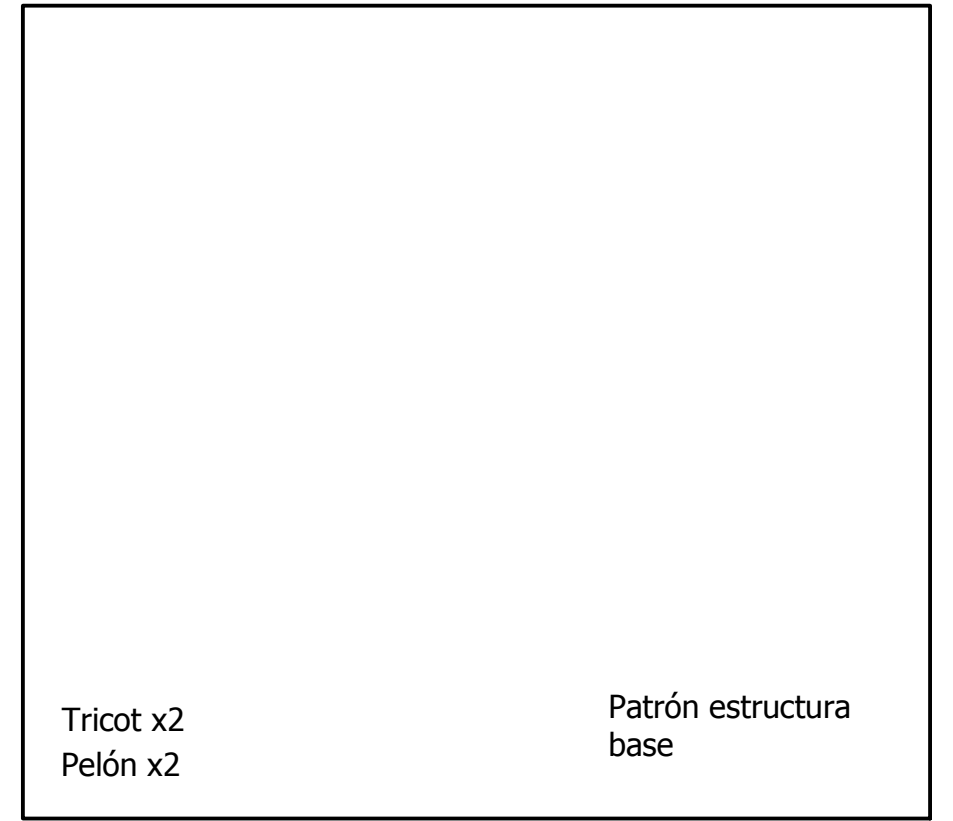

esc. 1:10

Costura recta



esc. 1:20



Pontificia Universidad Católica del Ecuador			Contiene: 12 de 14
Diseño de Productos			Formato: A3
	Contiene:		
Dibujado por: Priscila Aguinaga H.	Medida en mm	Fecha: Enero, 2019	Escala:

8 7 6 5 4 3 2 1

F  
E  
D  
C  
B  
A

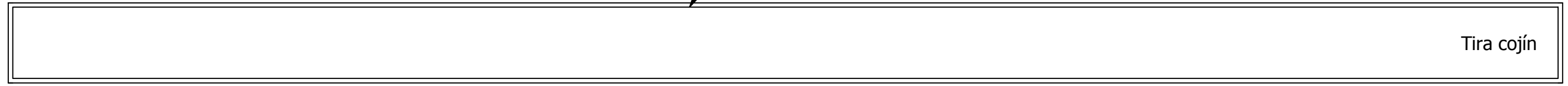
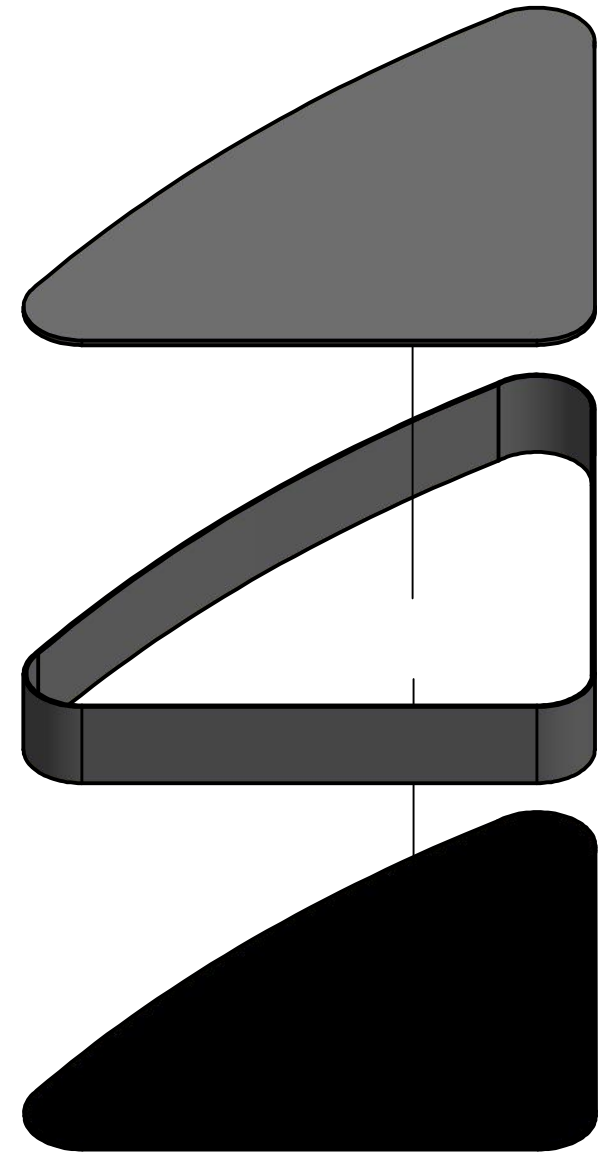
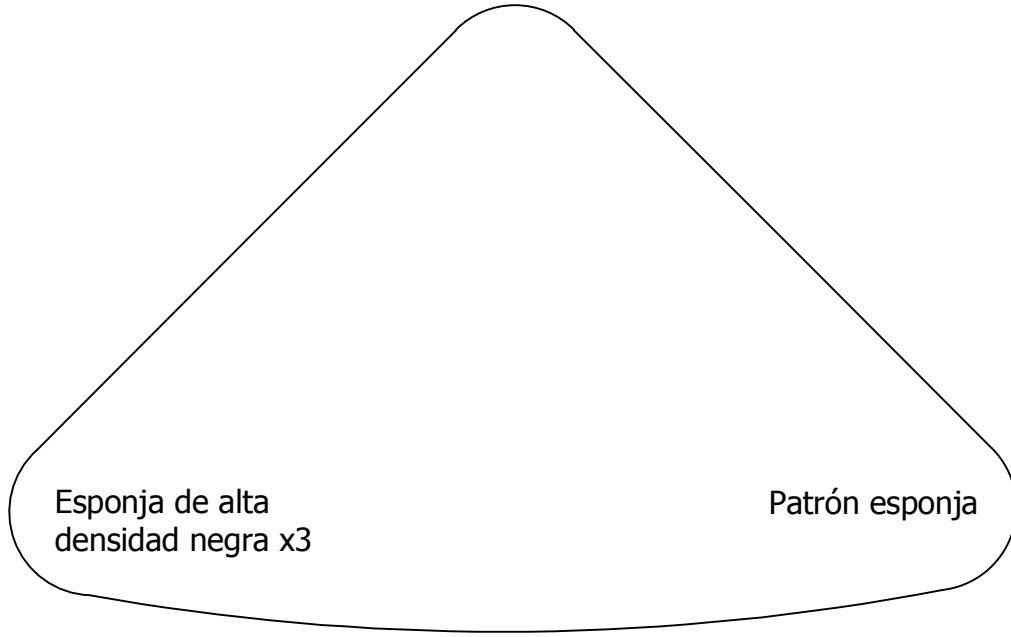
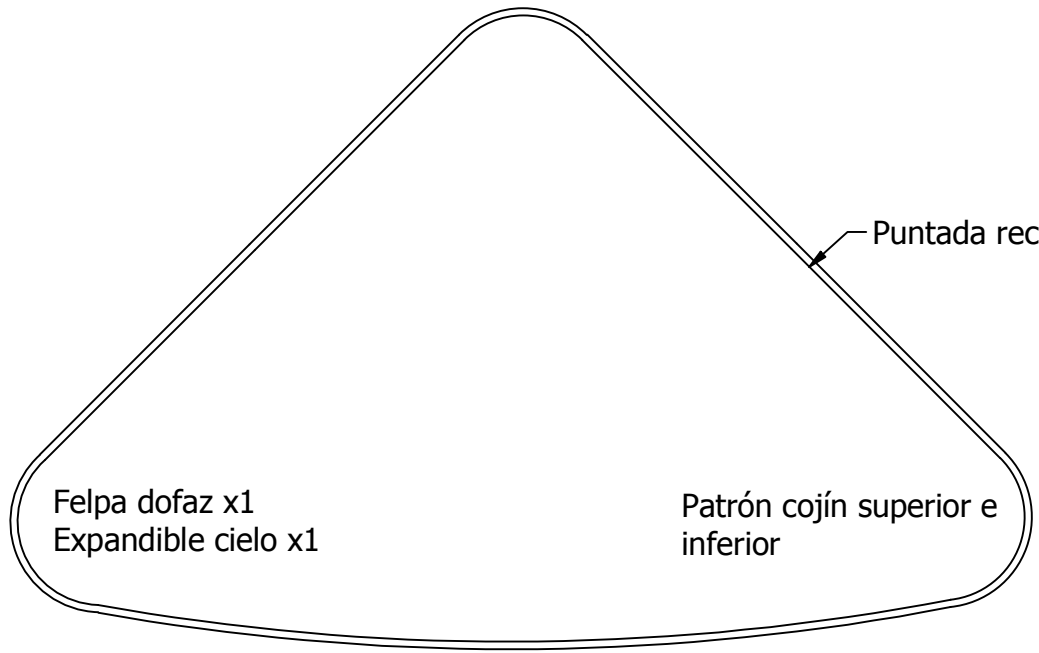

F  
E  
D  
C  
B  
A

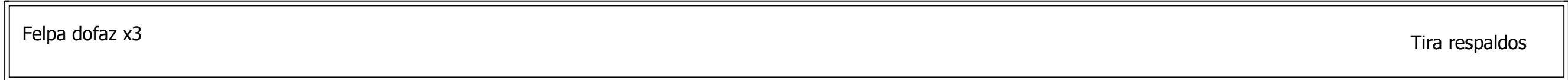
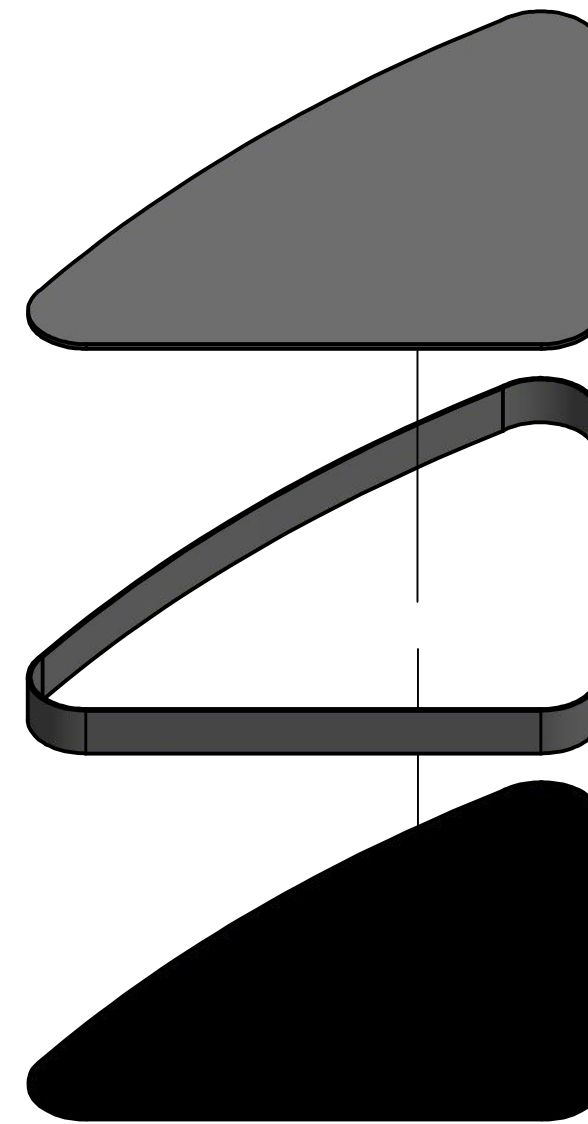
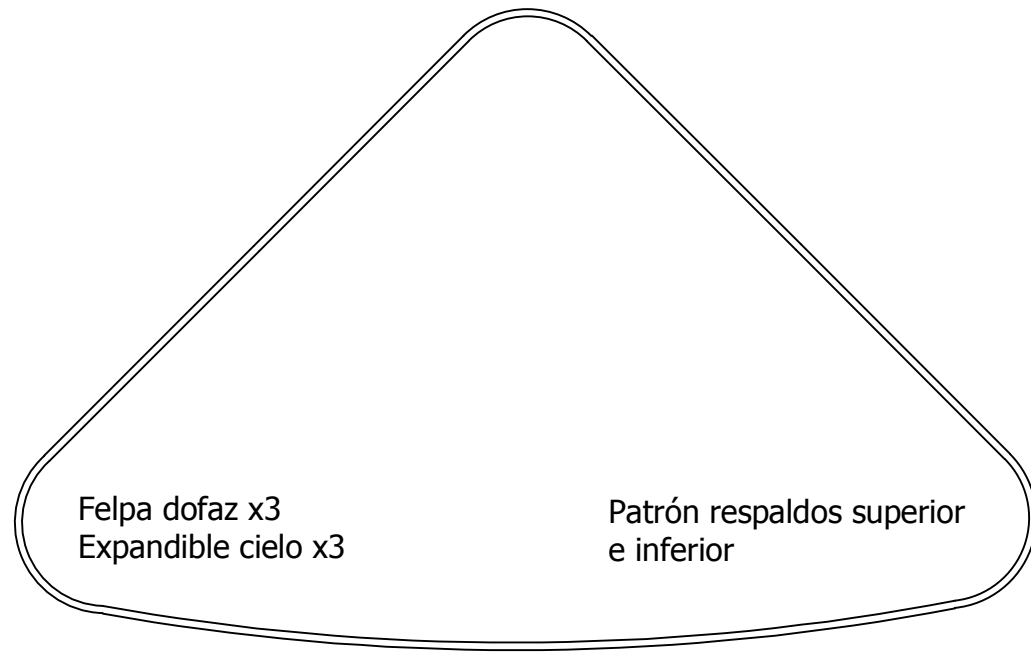

Pontificia Universidad Católica del Ecuador			Contiene: 13 de 14
Diseño de Productos			Formato: A3
	Contiene: Patronaje cojín		
Dibujado por: Priscila Aguinaga H.	Medida en mm	Fecha: Enero, 2019	Escala: 1:10

8 7 6 5 4 3 2 1



Pontificia Universidad Católica del Ecuador			Contiene: 14 de 14
Diseño de Productos			Formato: A3
	Contiene: Patronaje respaldos		
Dibujado por: Priscila Aguinaga H.	Medida en mm	Fecha: Enero, 2019	Escala: 1:10