

PONTIFICIA UNIVERSIDAD CATÓLICA DEL ECUADOR
FACULTAD DE ARQUITECTURA, DISEÑO Y ARTES
CARRERA DE DISEÑO DE PRODUCTOS

TORABAG

PLANOS TÉCNICOS Y PROCESO PRODUCTIVO

María Pia Vela

“DISEÑO DE UNA FAMILIA DE OBJETOS ECO AMIGABLES PARA TRABAJO EN CASA QUE REVALORICEN LOS TEXTILES TRADICIONALES DEL ECUADOR”

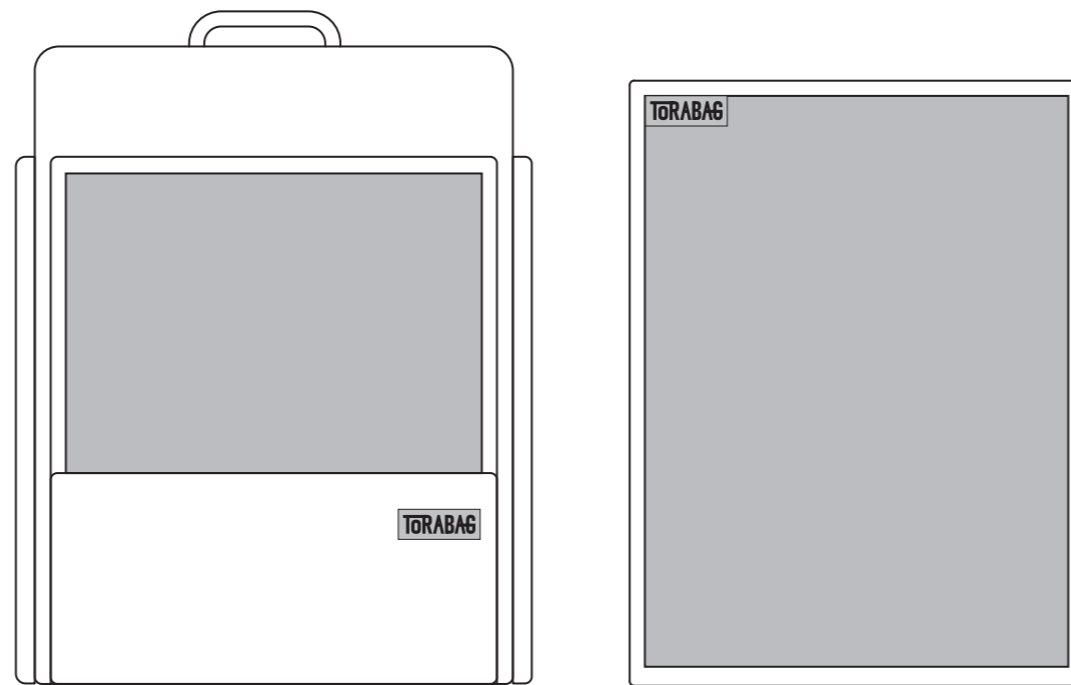

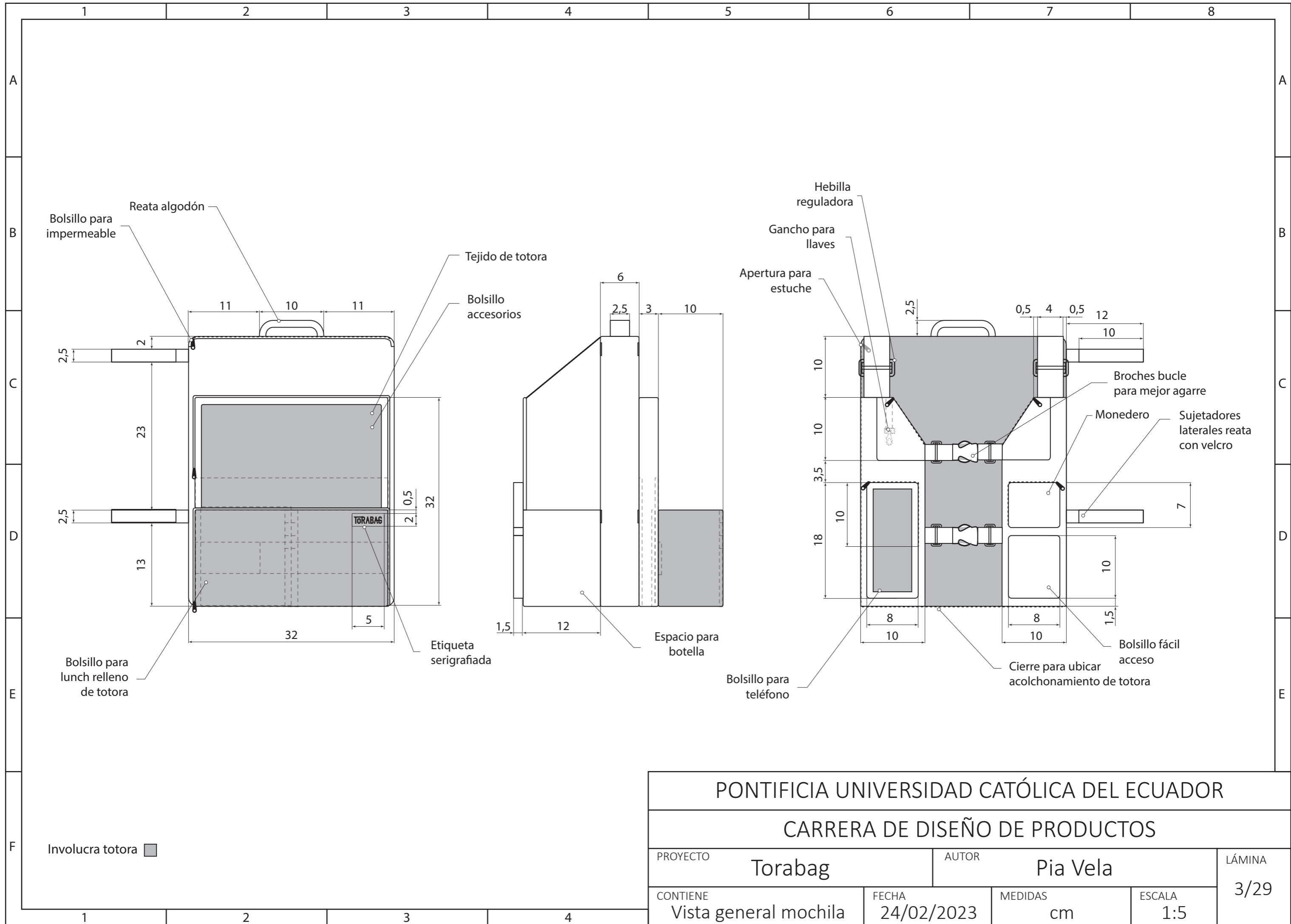

PONTIFICIA UNIVERSIDAD CATÓLICA DEL ECUADOR			
CARRERA DE DISEÑO DE PRODUCTOS			
PROYECTO	Torabag	AUTOR	Pia Vela
CONTIENE	Vista general mochila	FECHA	24/02/2023
		MEDIDAS	cm
		ESCALA	1:5
		LÁMINA	3/29

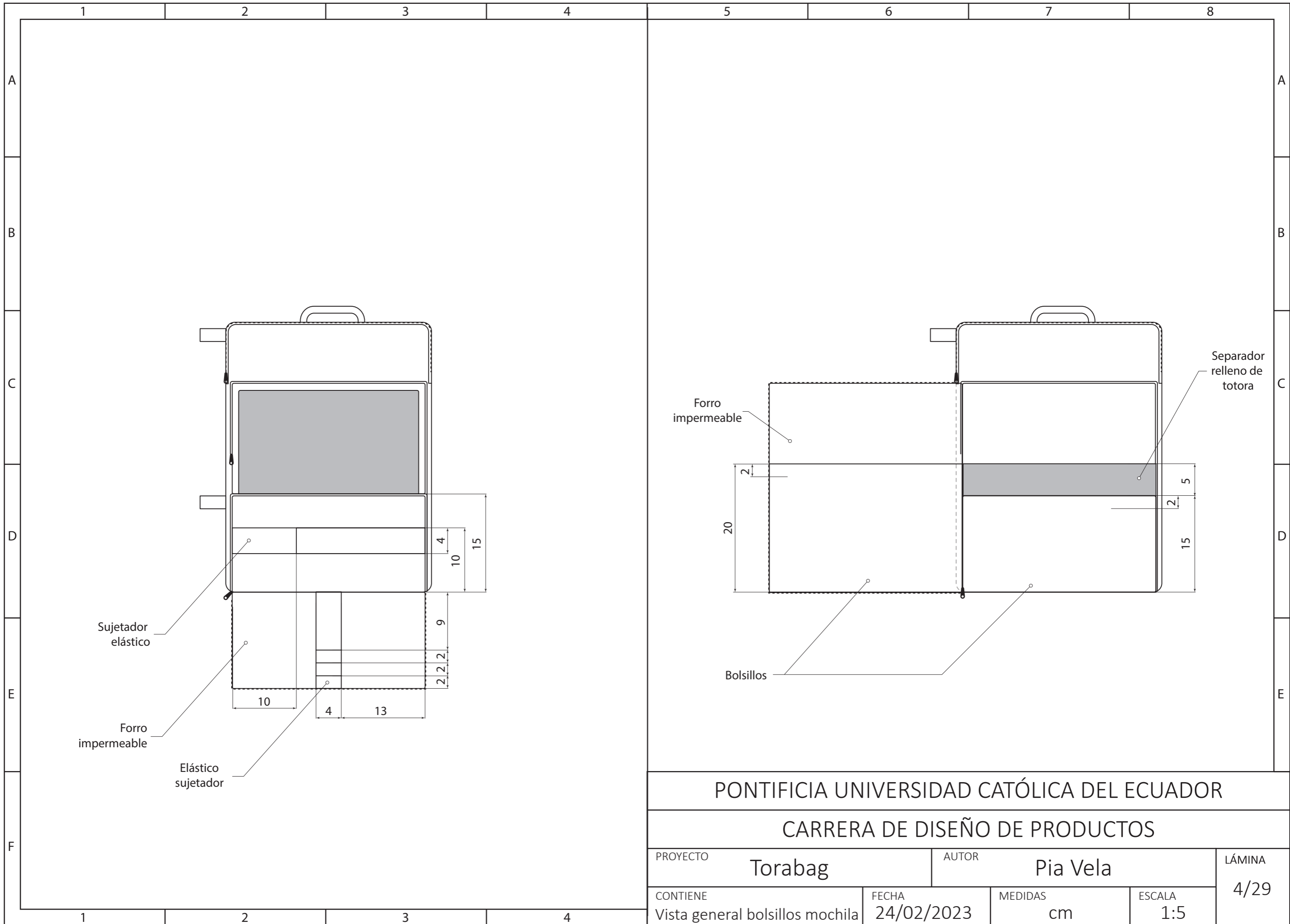

PONTIFICIA UNIVERSIDAD CATÓLICA DEL ECUADOR

CARRERA DE DISEÑO DE PRODUCTOS

PROYECTO	Torabag	AUTOR	Pia Vela	LÁMINA
CONTIENE	Vista general bolsillos mochila	FECHA	24/02/2023	4/29
		MEDIDAS	cm	ESCALA
				1:5

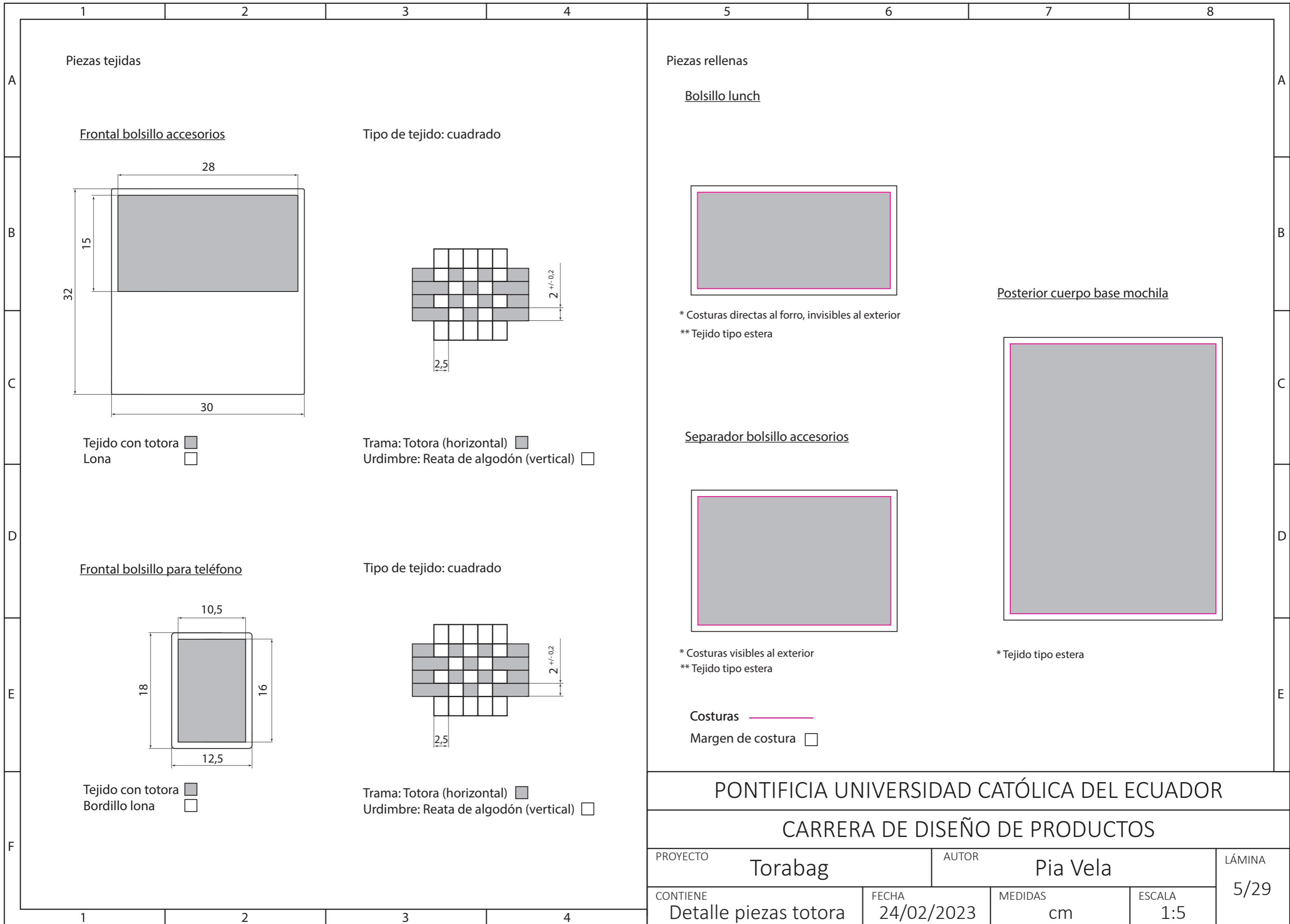

PONTIFICIA UNIVERSIDAD CATÓLICA DEL ECUADOR

CARRERA DE DISEÑO DE PRODUCTOS

PROYECTO	Torabag	AUTOR	Pia Vela	LÁMINA	5/29
CONTIENE	Detalle piezas totora	FECHA	24/02/2023	MEDIDAS	cm
			ESCALA	1:5	

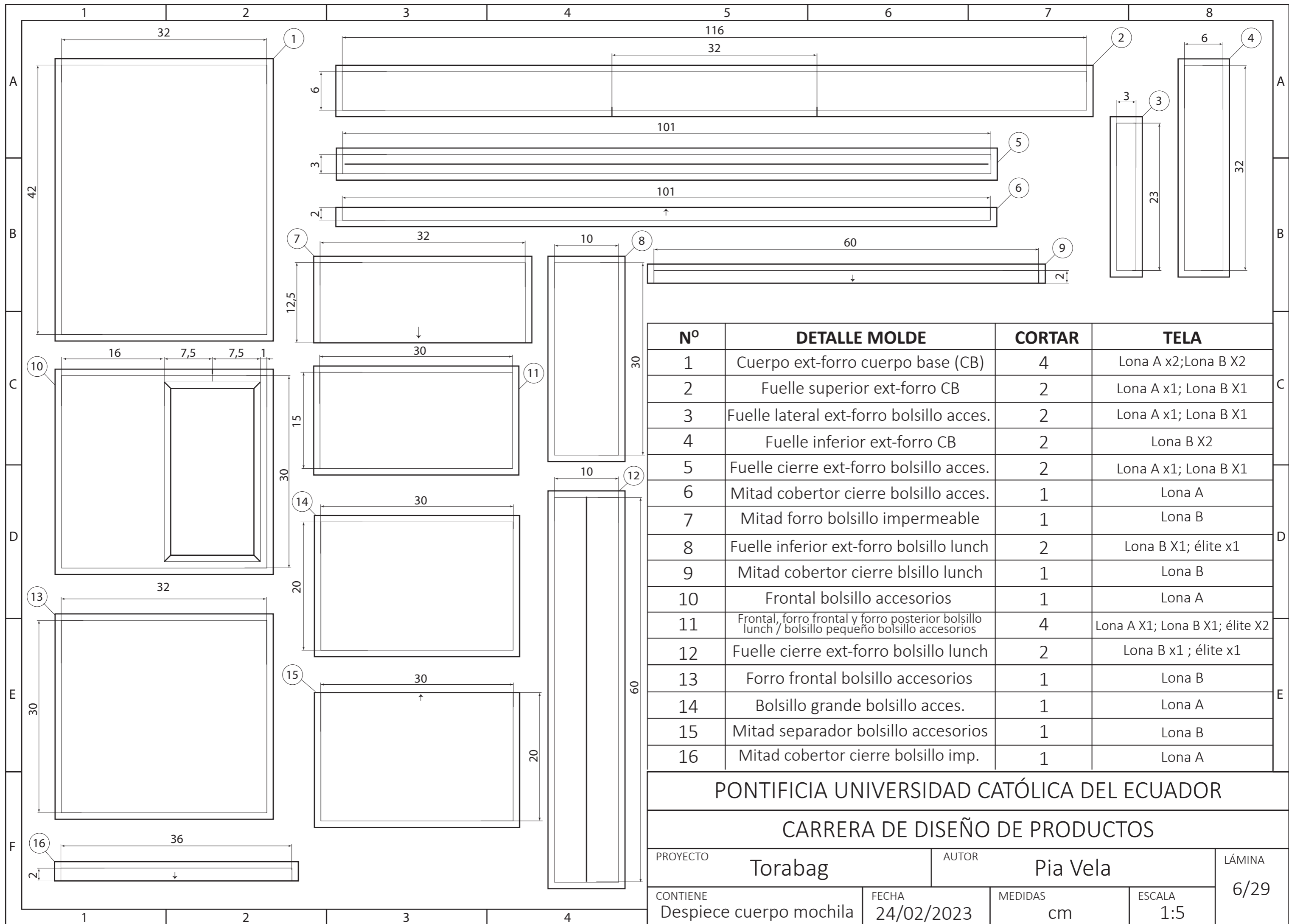

Nº	DETALLE MOLDE	CORTAR	TELA
1	Cuerpo ext-forro cuerpo base (CB)	4	Lona A x2; Lona B X2
2	Fuelle superior ext-forro CB	2	Lona A x1; Lona B X1
3	Fuelle lateral ext-forro bolsillo acces.	2	Lona A x1; Lona B X1
4	Fuelle inferior ext-forro CB	2	Lona B X2
5	Fuelle cierre ext-forro bolsillo acces.	2	Lona A x1; Lona B X1
6	Mitad cobertor cierre bolsillo acces.	1	Lona A
7	Mitad forro bolsillo impermeable	1	Lona B
8	Fuelle inferior ext-forro bolsillo lunch	2	Lona B X1; elite x1
9	Mitad cobertor cierre bolsillo lunch	1	Lona B
10	Frontal bolsillo accesorios	1	Lona A
11	Frontal, forro frontal y forro posterior bolsillo lunch / bolsillo pequeño bolsillo accesorios	4	Lona A X1; Lona B X1; elite X2
12	Fuelle cierre ext-forro bolsillo lunch	2	Lona B x1 ; elite x1
13	Forro frontal bolsillo accesorios	1	Lona B
14	Bolsillo grande bolsillo acces.	1	Lona A
15	Mitad separador bolsillo accesorios	1	Lona B
16	Mitad cobertor cierre bolsillo imp.	1	Lona A

PONTIFICIA UNIVERSIDAD CATÓLICA DEL ECUADOR

CARRERA DE DISEÑO DE PRODUCTOS

PROYECTO	Torabag	AUTOR	Pia Vela	LÁMINA	6/29
CONTIENE	Despiece cuerpo mochila	FECHA	24/02/2023	MEDIDAS	cm
		ESCALA	1:5		

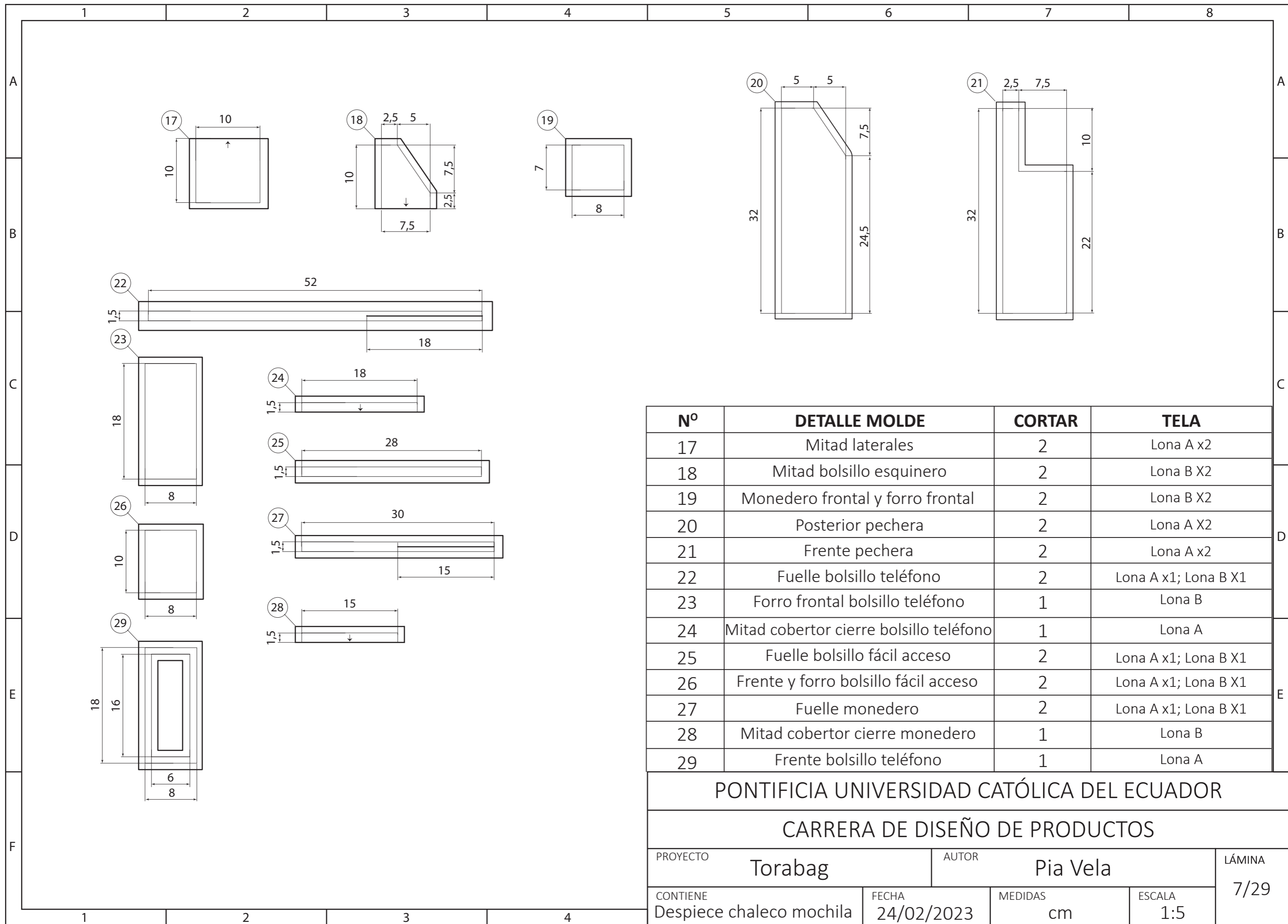

PONTIFICIA UNIVERSIDAD CATÓLICA DEL ECUADOR

CARRERA DE DISEÑO DE PRODUCTOS

PROYECTO	Torabag	AUTOR	Pia Vela	LÁMINA
CONTIENE	Despiece chaleco mochila	FECHA	24/02/2023	7/29
		MEDIDAS	cm	ESCALA
				1:5

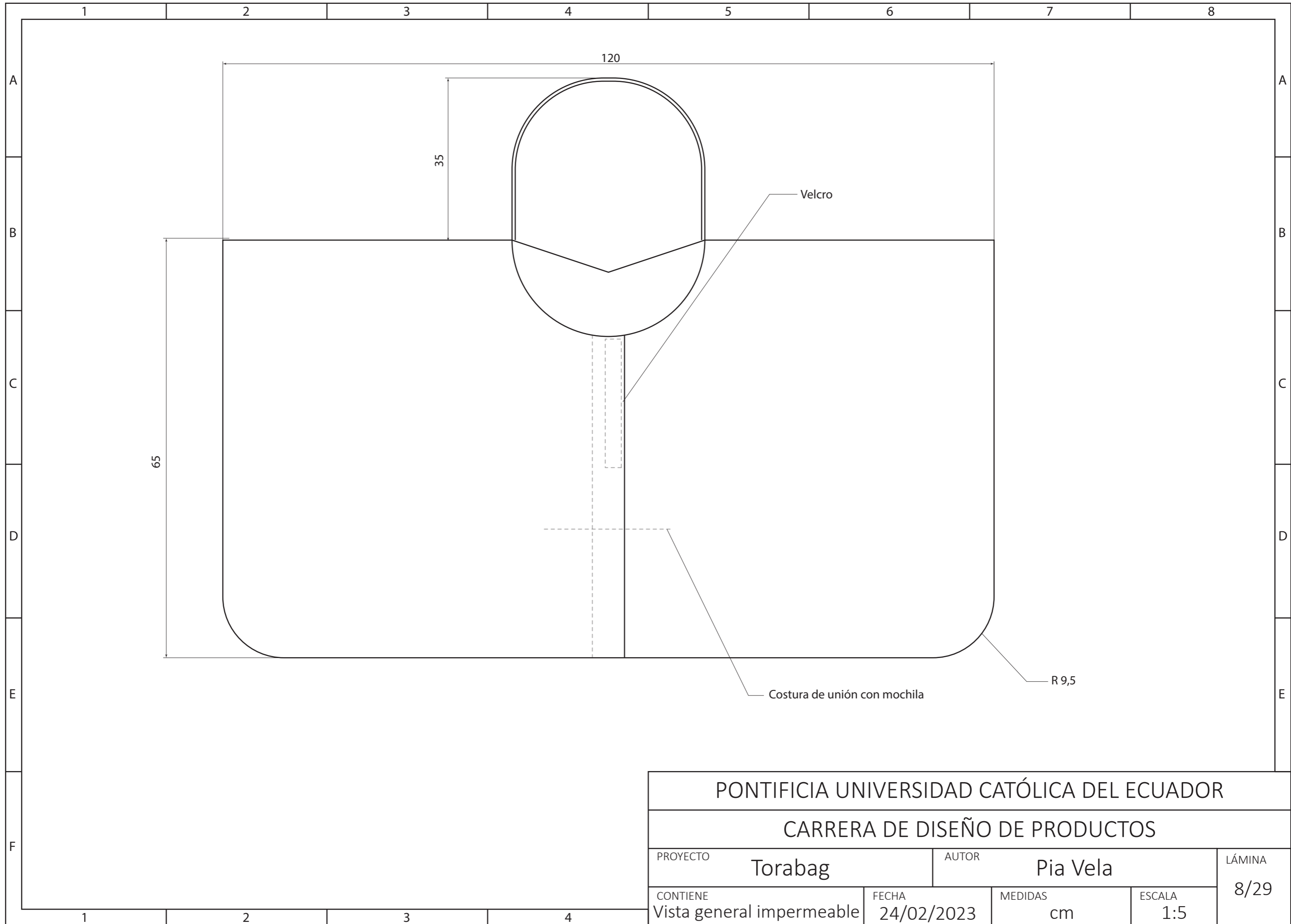

PONTIFICIA UNIVERSIDAD CATÓLICA DEL ECUADOR

CARRERA DE DISEÑO DE PRODUCTOS

PROYECTO	Torabag	AUTOR	Pia Vela	LÁMINA
CONTIENE	Vista general impermeable	FECHA	24/02/2023	8/29
		MEDIDAS	cm	ESCALA
				1:5

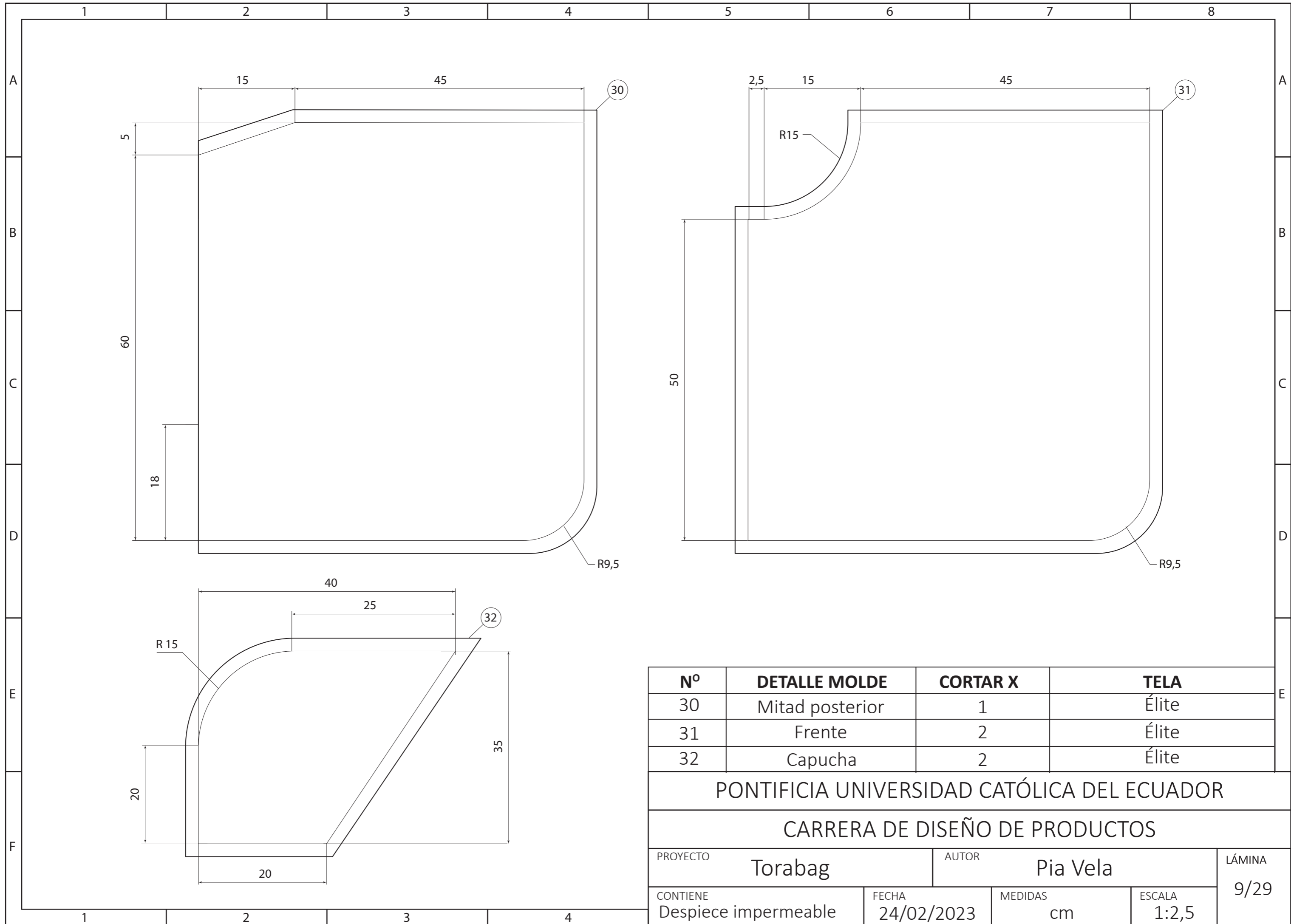

Nº	DETALLE MOLDE	CORTAR X	TELA
30	Mitad posterior	1	Élite
31	Frente	2	Élite
32	Capucha	2	Élite

PONTIFICIA UNIVERSIDAD CATÓLICA DEL ECUADOR			
CARRERA DE DISEÑO DE PRODUCTOS			
PROYECTO	Torabag	AUTOR	Pia Vela
CONTIENE	Despiece impermeable	FECHA	24/02/2023
MEDIDAS	cm	ESCALA	1:2,5
			LÁMINA 9/29

1	2	3	4	5	6	7	8																																																
TEJIDOS																																																							
NOMBRE COMERCIAL	COMPOSICIÓN	ANCHO	PRECIO X METRO	PROVEEDOR	UBICACIÓN	TONO A	TONO B																																																
Élite impermeable	100% poliester	150	\$2,90	Casa de las telas	1-5, 7, 8, 11-13, 15, 16, 18, 19, 22-27, 31-33	Palo de rosa	Lila																																																
Lona	100% algodón	160	\$5,90	Casa de las telas	1-3, 5, 6, 8-12, 14, 17, 19-22, 24-29	kaki safari / Azul índigo	Palo de rosa / morado																																																
Totora	-	varas de 2cm ^{+/-0,2}	\$10 por todas las piezas	Totora Wasi	1, 8, 10, 11, 15, 29	Crudo	Crudo																																																
AVÍOS																																																							
NOMBRE COMERCIAL	COMPOSICIÓN	PRECIO	PROVEEDOR	CANTIDAD	UBICACIÓN	CROMÁTICA CÁLIDA	CROMÁTICA FRÍA																																																
Cadena cierre continua	Poliester	\$0,15 x m	La casa del cierre	3 metros	1, 5, 7, 12, 22, 27	G8 o C4	E12 o D1																																																
Deslizador	Poliester	\$0,10 c/u	La casa del cierre	6	1, 5, 7, 12, 22, 27	G8 o C4	E12 o D1																																																
Reata algodón 2,5cm	100% algodón	\$1,25 x m	Insumoda	3 metros	sujetadores laterales, frontales, superior y tejido con totora	Tinte iris No.47 kaki safari	Tinte iris No.17 Azul oscuro																																																
Hebilla reguladora 4cm	Niquel	\$0,4 c/u	Konamtex	2	Reata 5cm	X	X																																																
Hebilla reguladora 3cm	Niquel	\$0,4 c/u	Konamtex	4	En reata de sujetadores frontales	X	X																																																
Reata 5cm	100% algodón	\$1,75 x m	Insumoda	1 metro	Unión 1 con 20	Tinte iris No.47 kaki safari	Tinte iris No.17 Azul oscuro																																																
Velcro 2,5 cm	Nylon y poliester	\$0,8 xm	Insumoda	20 cm	sujetadores laterales	Negro	Negro																																																
Elástico 4 cm	Nylon	\$2,25 x m	Insumoda	35 cm	11, 18	Negro	Negro																																																
Mosquetón	Niquel	\$0,50 c/u	Insumoda	1	en elástico 2cm (18)	Niquel	Niquel																																																
Broche tipo bucle	Poliester	\$0,40 c/u	Insumoda	2	En reata de sujetadores frontales	Negro	Negro																																																
Etiqueta	Algodón	\$0,10 c/u	Marcas_etiquetas	1	11 frontal bolsillo lunch	Crudo/tinta negra	Crudo/tinta negra																																																
Tinte textil Iris eco	-	\$1,5 c/u	Insumoda	4	Todo textil lona	Kaki Safari y Palo de rosa	Azul índigo y Palo de rosa																																																
<table border="1" style="width: 100%; border-collapse: collapse;"> <tr> <td colspan="8" style="text-align: center;">PONTIFICIA UNIVERSIDAD CATÓLICA DEL ECUADOR</td> </tr> <tr> <td colspan="8" style="text-align: center;">CARRERA DE DISEÑO DE PRODUCTOS</td> </tr> <tr> <td colspan="4" style="text-align: center;">PROYECTO Torabag</td> <td colspan="4" style="text-align: center;">AUTOR Pia Vela</td> </tr> <tr> <td colspan="4" style="text-align: center;">CONTIENE Ficha de materiales mochila</td> <td colspan="2" style="text-align: center;">FECHA 24/02/2023</td> <td colspan="2" style="text-align: center;">MEDIDAS cm</td> </tr> <tr> <td colspan="6"></td> <td colspan="2" style="text-align: center;">LÁMINA 10/29</td> </tr> <tr> <td colspan="6"></td> <td colspan="2" style="text-align: center;">ESCALA -</td> </tr> </table>								PONTIFICIA UNIVERSIDAD CATÓLICA DEL ECUADOR								CARRERA DE DISEÑO DE PRODUCTOS								PROYECTO Torabag				AUTOR Pia Vela				CONTIENE Ficha de materiales mochila				FECHA 24/02/2023		MEDIDAS cm								LÁMINA 10/29								ESCALA -	
PONTIFICIA UNIVERSIDAD CATÓLICA DEL ECUADOR																																																							
CARRERA DE DISEÑO DE PRODUCTOS																																																							
PROYECTO Torabag				AUTOR Pia Vela																																																			
CONTIENE Ficha de materiales mochila				FECHA 24/02/2023		MEDIDAS cm																																																	
						LÁMINA 10/29																																																	
						ESCALA -																																																	

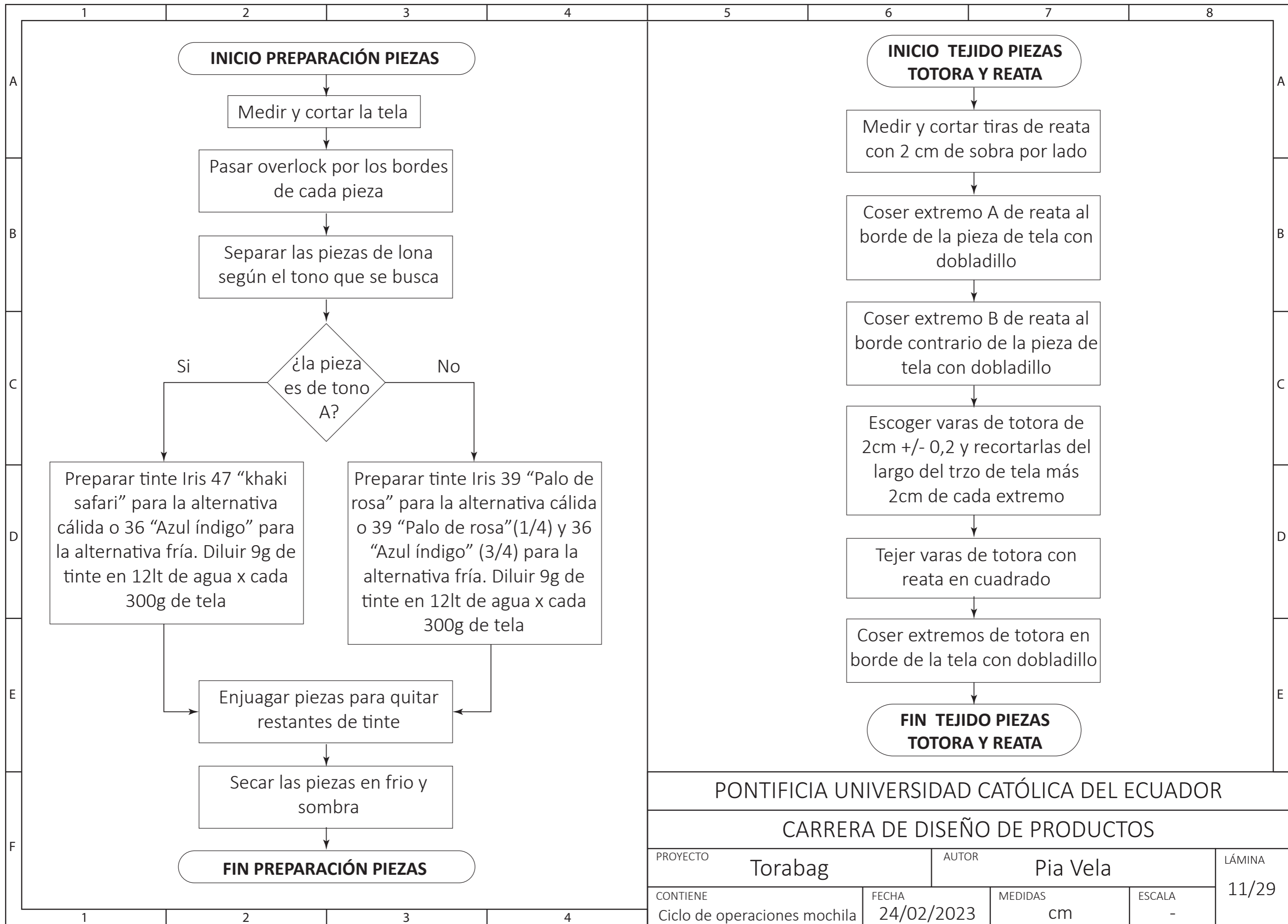

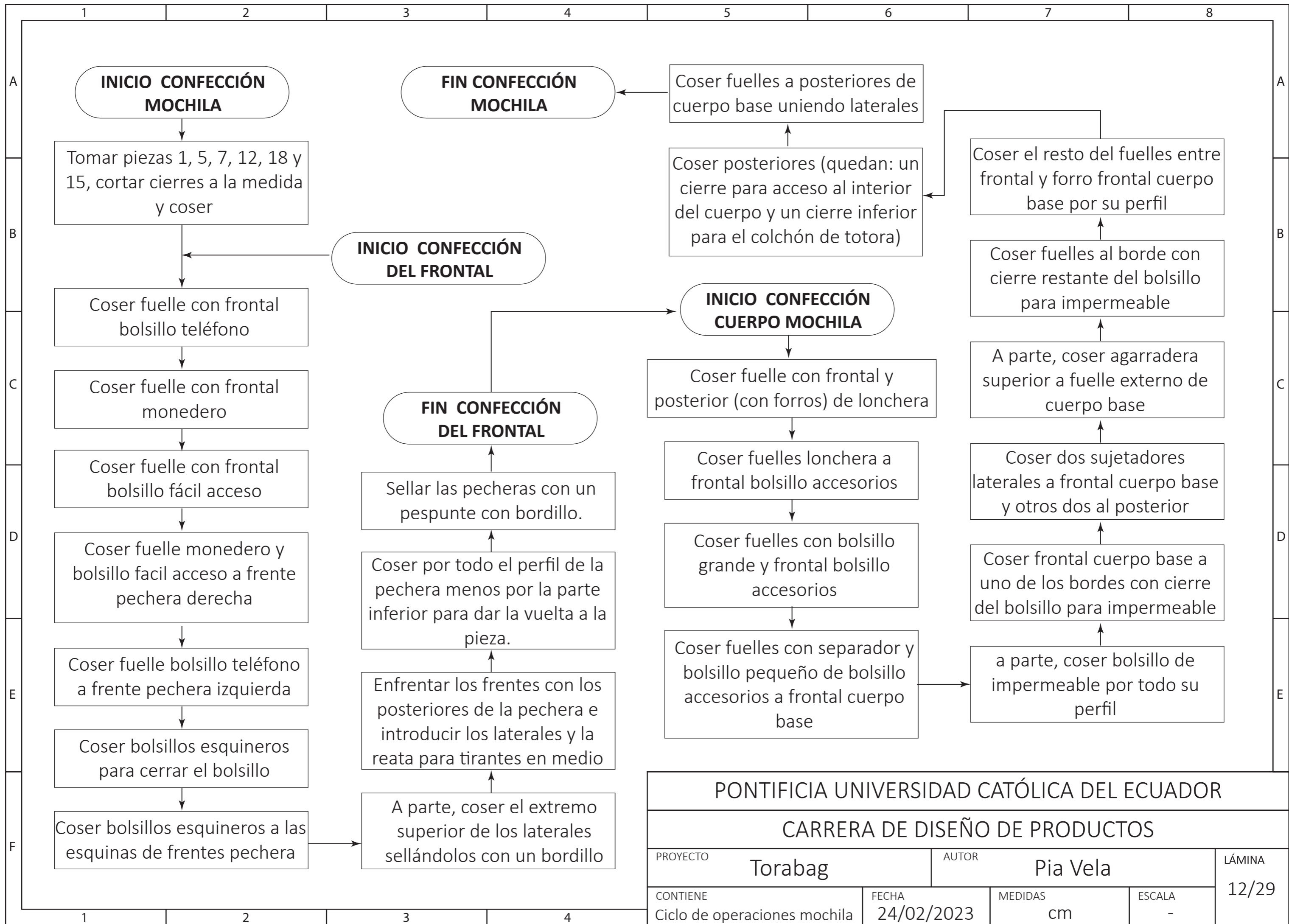

PONTIFICIA UNIVERSIDAD CATÓLICA DEL ECUADOR				
CARRERA DE DISEÑO DE PRODUCTOS				
PROYECTO	Torabag		AUTOR	Pia Vela
CONTIENE	FECHA	MEDIDAS	ESCALA	LÁMINA
Ciclo de operaciones mochila	24/02/2023	cm	-	12/29

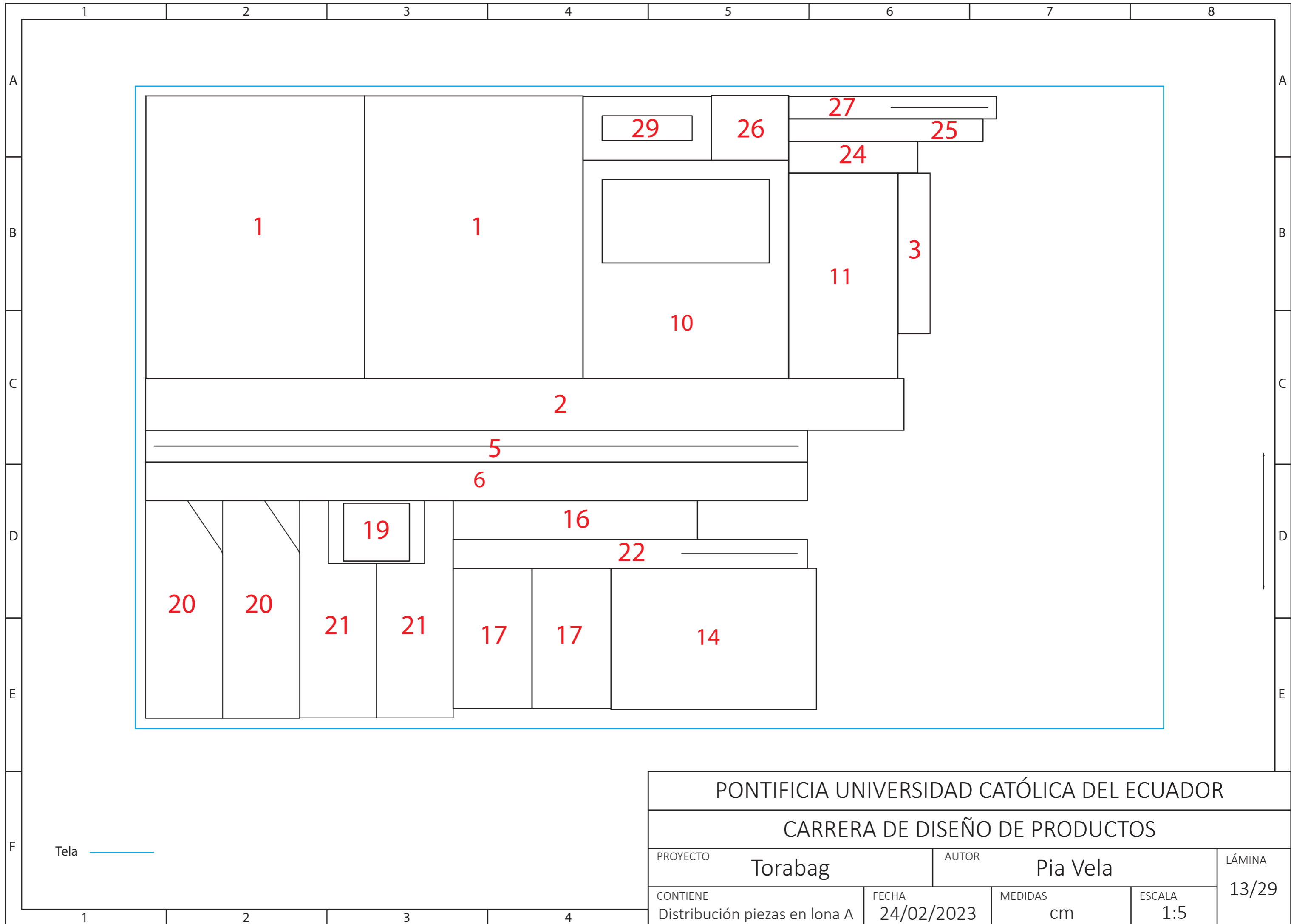

PONTIFICIA UNIVERSIDAD CATÓLICA DEL ECUADOR			
CARRERA DE DISEÑO DE PRODUCTOS			
PROYECTO	Torabag	AUTOR	Pia Vela
CONTIENE	Distribución piezas en lona A	FECHA	24/02/2023
		MEDIDAS	cm
		ESCALA	1:5
		LÁMINA	13/29

Tela

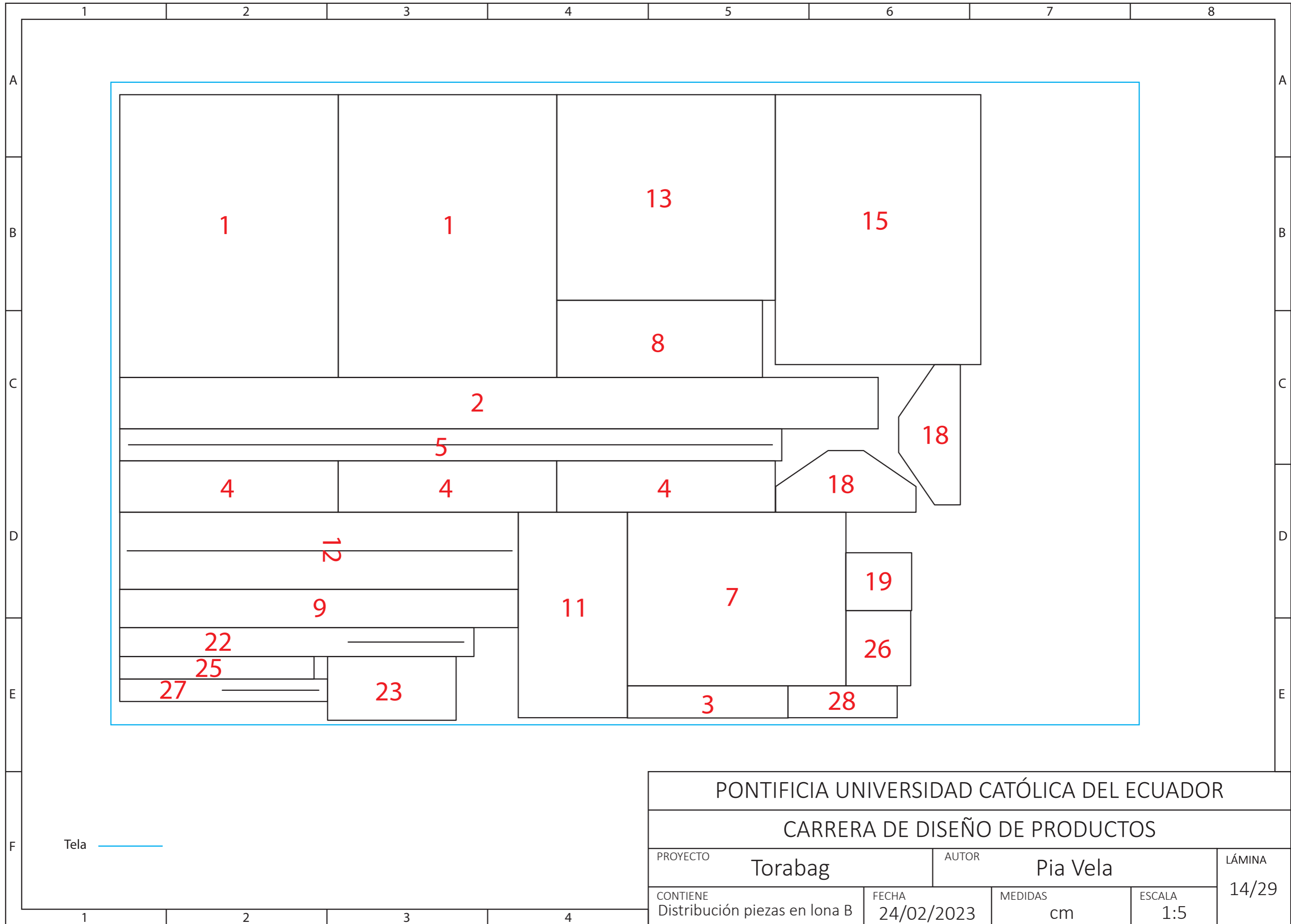

PONTIFICIA UNIVERSIDAD CATÓLICA DEL ECUADOR

CARRERA DE DISEÑO DE PRODUCTOS

PROYECTO	Torabag	AUTOR	Pia Vela	LÁMINA
CONTIENE	Distribución piezas en lona B	FECHA	24/02/2023	14/29
		MEDIDAS	cm	ESCALA
				1:5

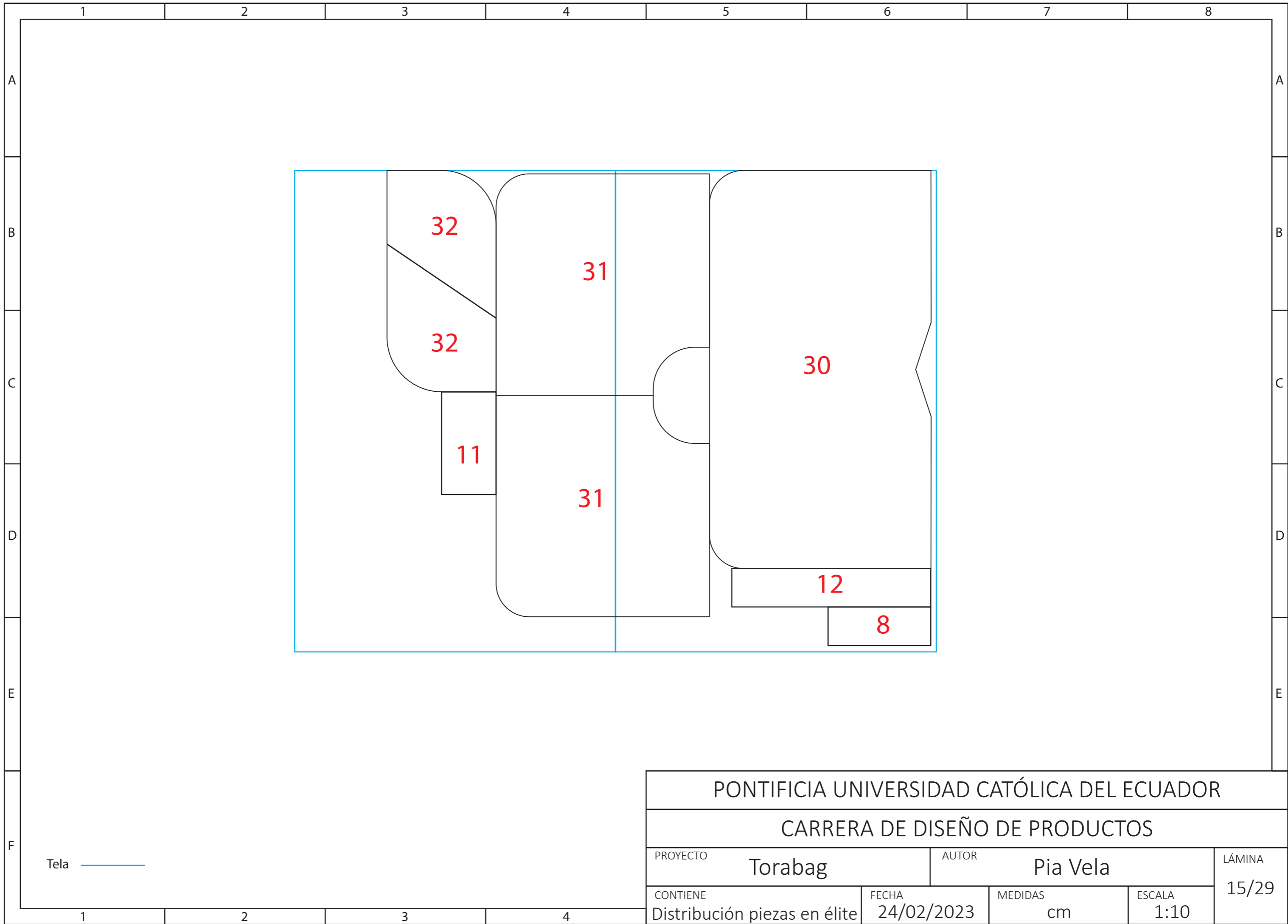

Tela

PONTIFICIA UNIVERSIDAD CATÓLICA DEL ECUADOR			
CARRERA DE DISEÑO DE PRODUCTOS			
PROYECTO	Torabag	AUTOR	Pia Vela
CONTIENE	FECHA	MEDIDAS	ESCALA
Distribución piezas en élite	24/02/2023	cm	1:10
			LÁMINA 15/29

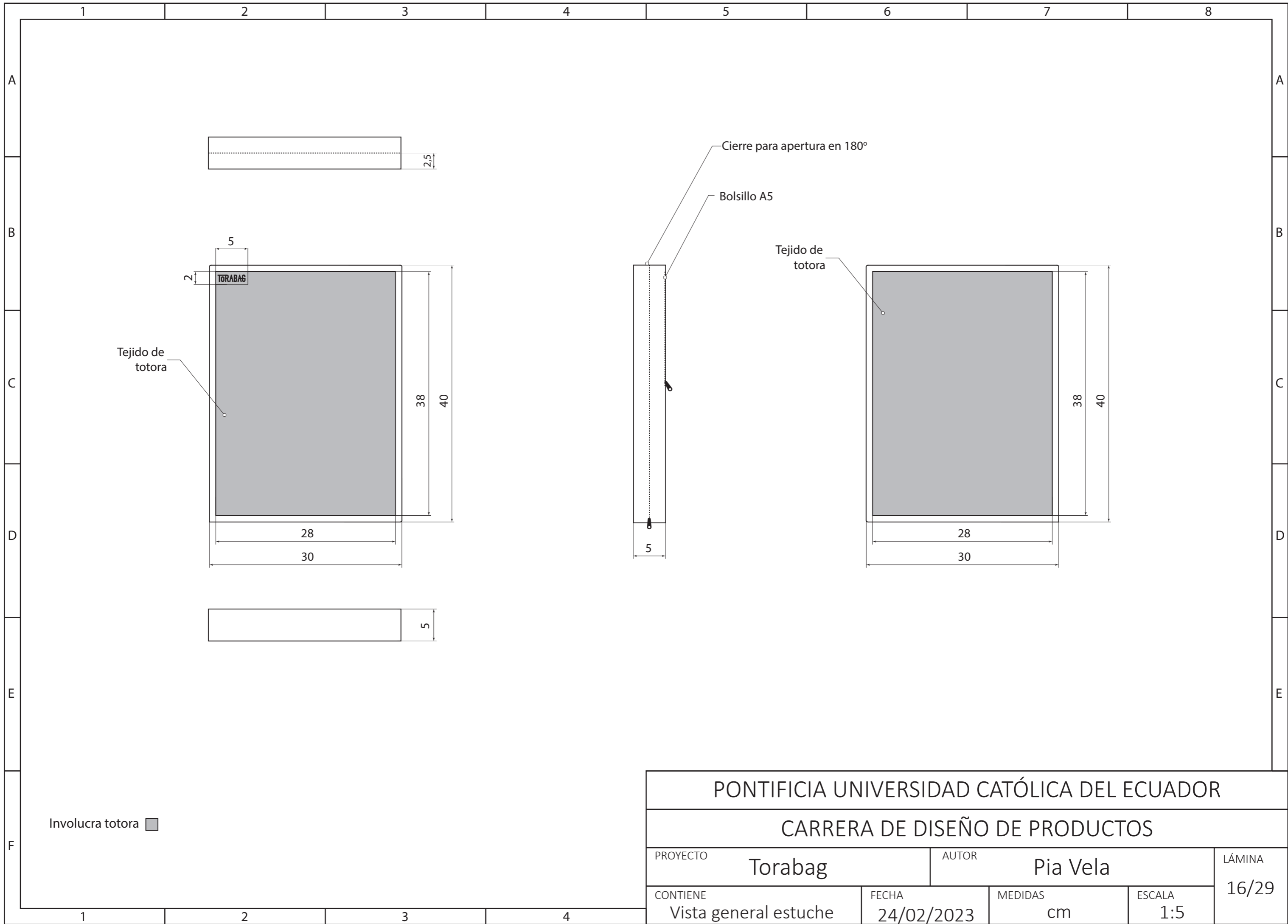

PONTIFICIA UNIVERSIDAD CATÓLICA DEL ECUADOR

CARRERA DE DISEÑO DE PRODUCTOS

PROYECTO	Torabag	AUTOR	Pia Vela	LÁMINA	16/29
CONTIENE	Vista general estuche	FECHA	24/02/2023	MEDIDAS	
				ESCALA	1:5

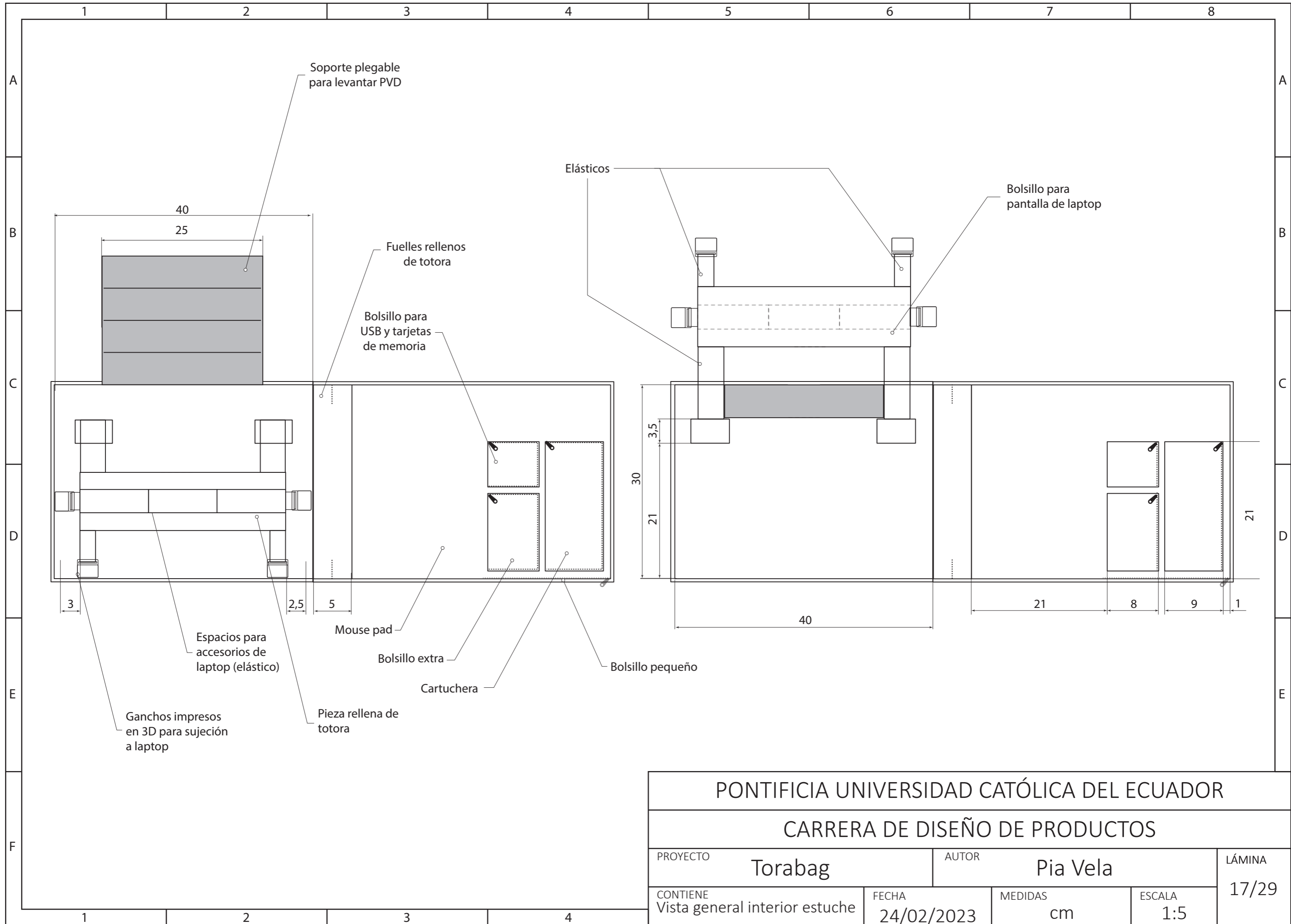

PONTIFICIA UNIVERSIDAD CATÓLICA DEL ECUADOR

CARRERA DE DISEÑO DE PRODUCTOS

PROYECTO	Torabag	AUTOR	Pia Vela	LÁMINA	17/29
CONTIENE	Vista general interior estuche	FECHA	24/02/2023	MEDIDAS	
				ESCALA	1:5

Gancho a pantalla laptop

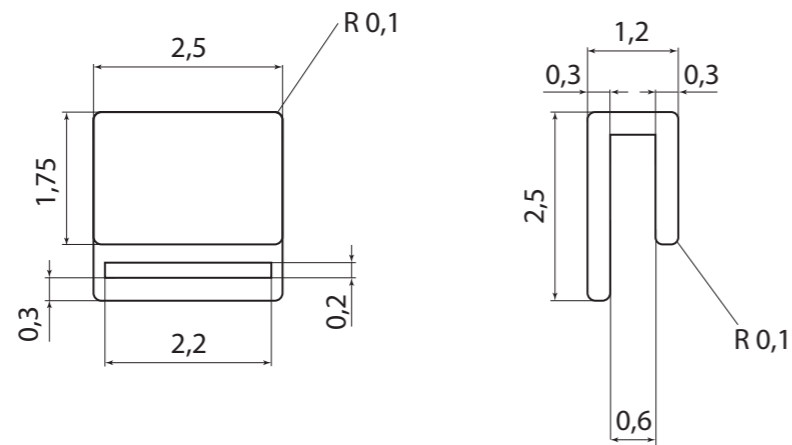

Bolsillo para pantalla de laptop

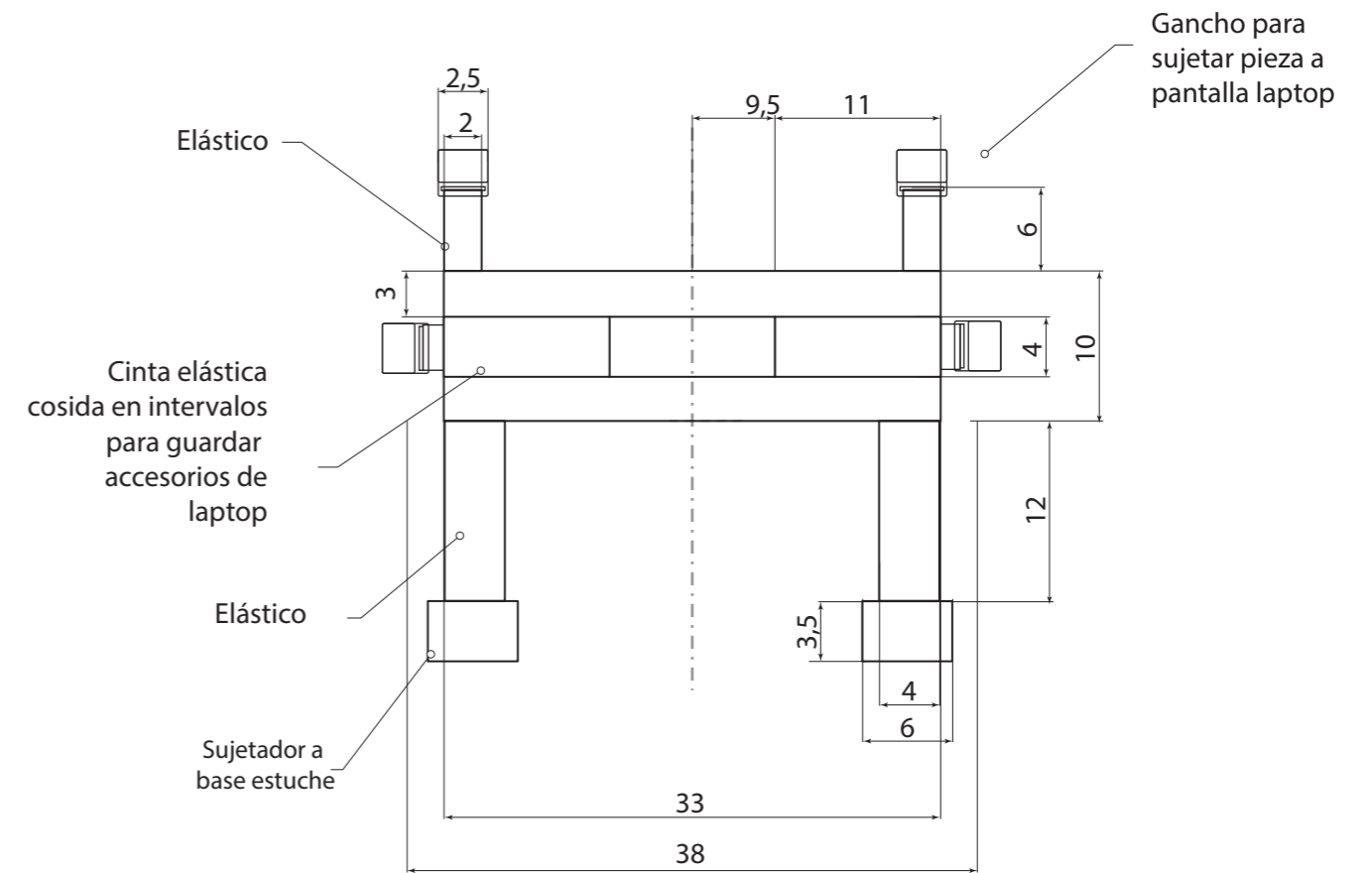

PONTIFICIA UNIVERSIDAD CATÓLICA DEL ECUADOR



CARRERA DE DISEÑO DE PRODUCTOS

PROYECTO	Torabag	AUTOR	Pia Vela	LÁMINA
CONTIENE	Vista general ganchos y bolsillo laptop	FECHA	24/02/2023	18/29
		MEDIDAS	cm	ESCALA
				1:1/1:5

Piezas rellenas

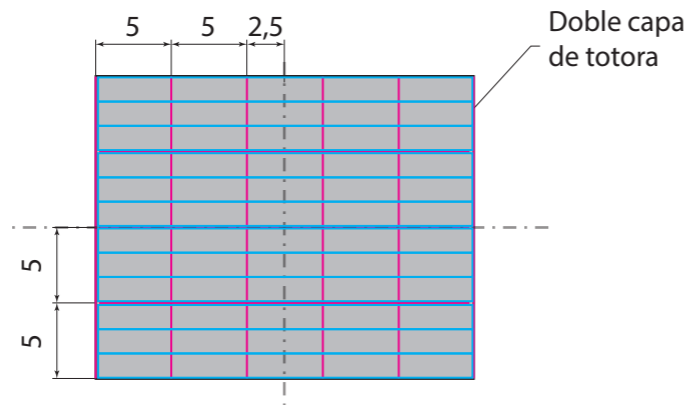
Soporte plegable para altura de PVD





Totora 
Costuras 
Margen de costura 

Piezas tejidas

Frontal estuche

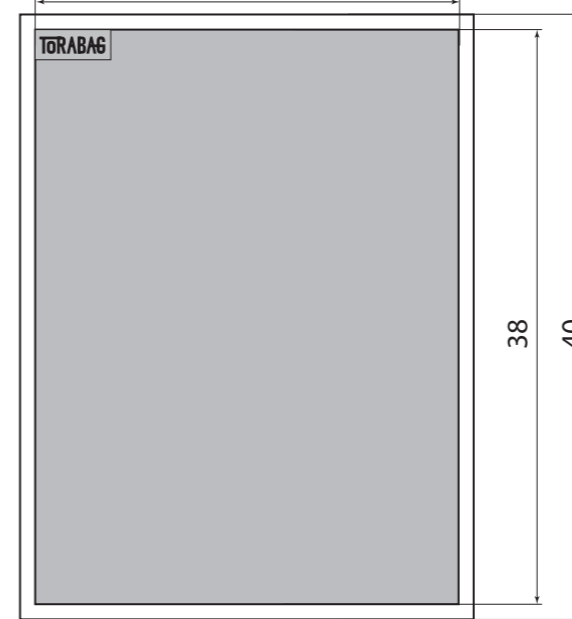

28

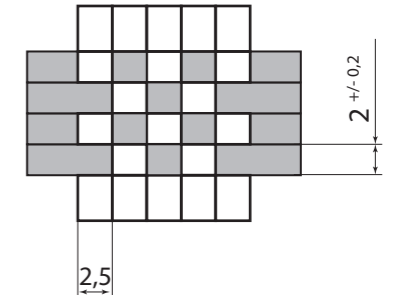

Tejido con totora 
Margen de tejido 

Tipo de tejido: cuadrado





Trama: Totora (horizontal) 
Urdimbre: Reata de algodón (vertical) 

Posterior estuche

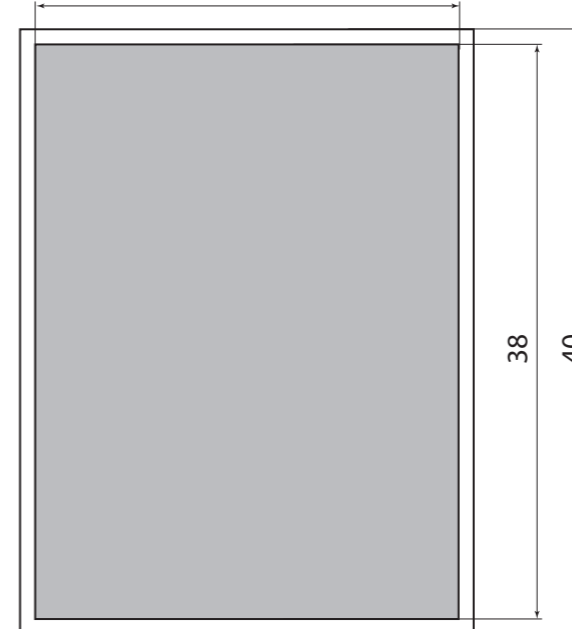

28

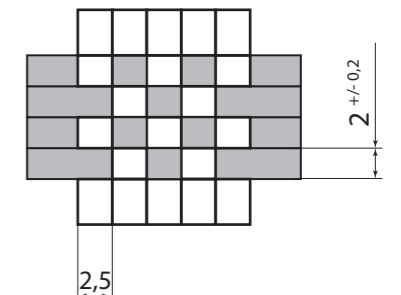

Tejido con totora 
Margen de tejido 

Tipo de tejido: cuadrado



Trama: Totora (horizontal) 
Urdimbre: Reata de algodón (vertical) 

PONTIFICIA UNIVERSIDAD CATÓLICA DEL ECUADOR

CARRERA DE DISEÑO DE PRODUCTOS

PROYECTO	Torabag	AUTOR	Pia Vela	LÁMINA	19/29
CONTIENE	Detalle piezas con totora	FECHA	24/02/2023	MEDIDAS	cm
				ESCALA	1:5

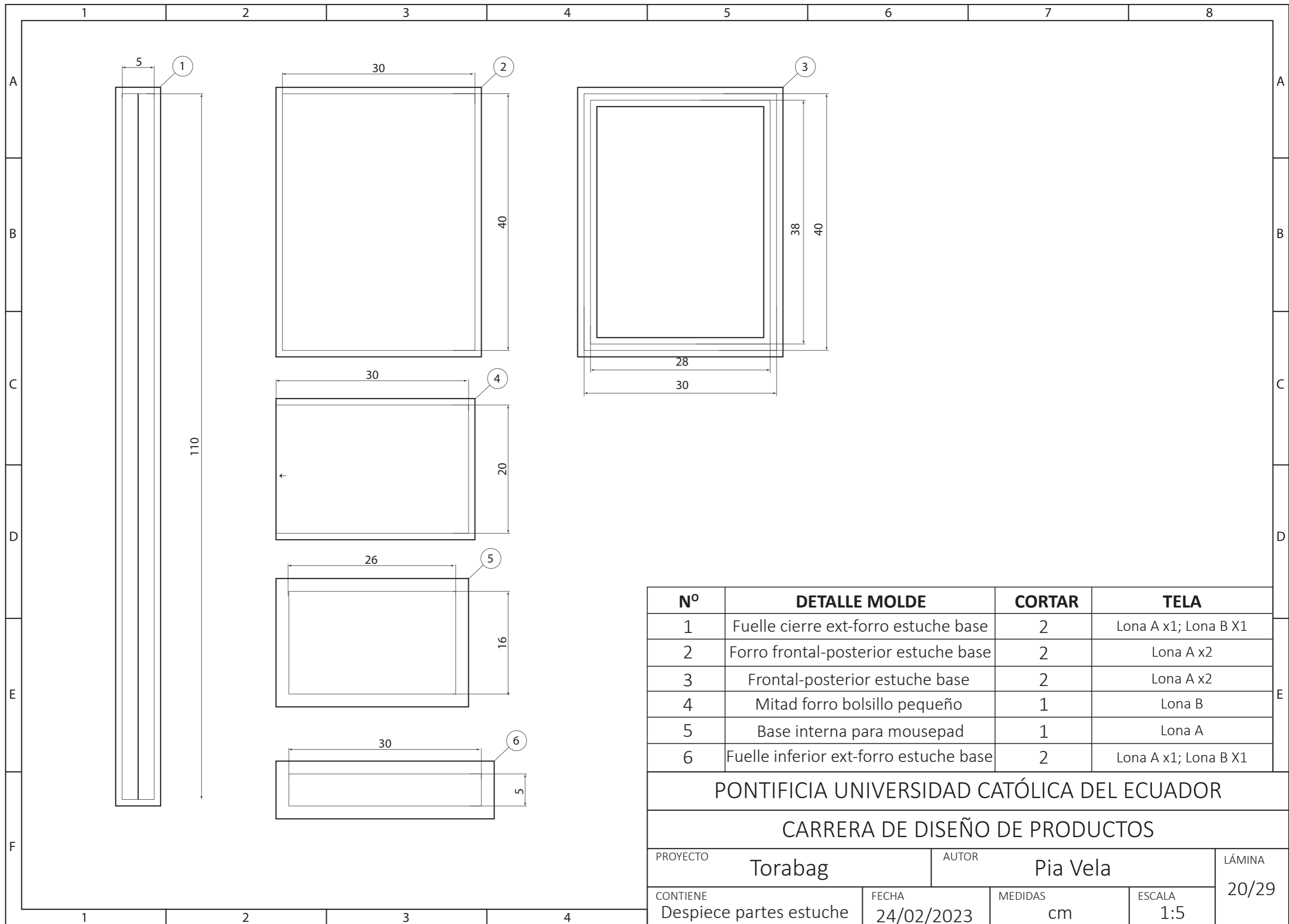

Nº	DETALLE MOLDE	CORTAR	TELA
1	Fuelle cierre ext-forro estuche base	2	Lona A x1; Lona B X1
2	Forro frontal-posterior estuche base	2	Lona A x2
3	Frontal-posterior estuche base	2	Lona A x2
4	Mitad forro bolsillo pequeño	1	Lona B
5	Base interna para mousepad	1	Lona A
6	Fuelle inferior ext-forro estuche base	2	Lona A x1; Lona B X1

PONTIFICIA UNIVERSIDAD CATÓLICA DEL ECUADOR

CARRERA DE DISEÑO DE PRODUCTOS

PROYECTO	Torabag	AUTOR	Pia Vela	LÁMINA	20/29
CONTIENE	Despiece partes estuche	FECHA	24/02/2023	MEDIDAS	cm
				ESCALA	1:5

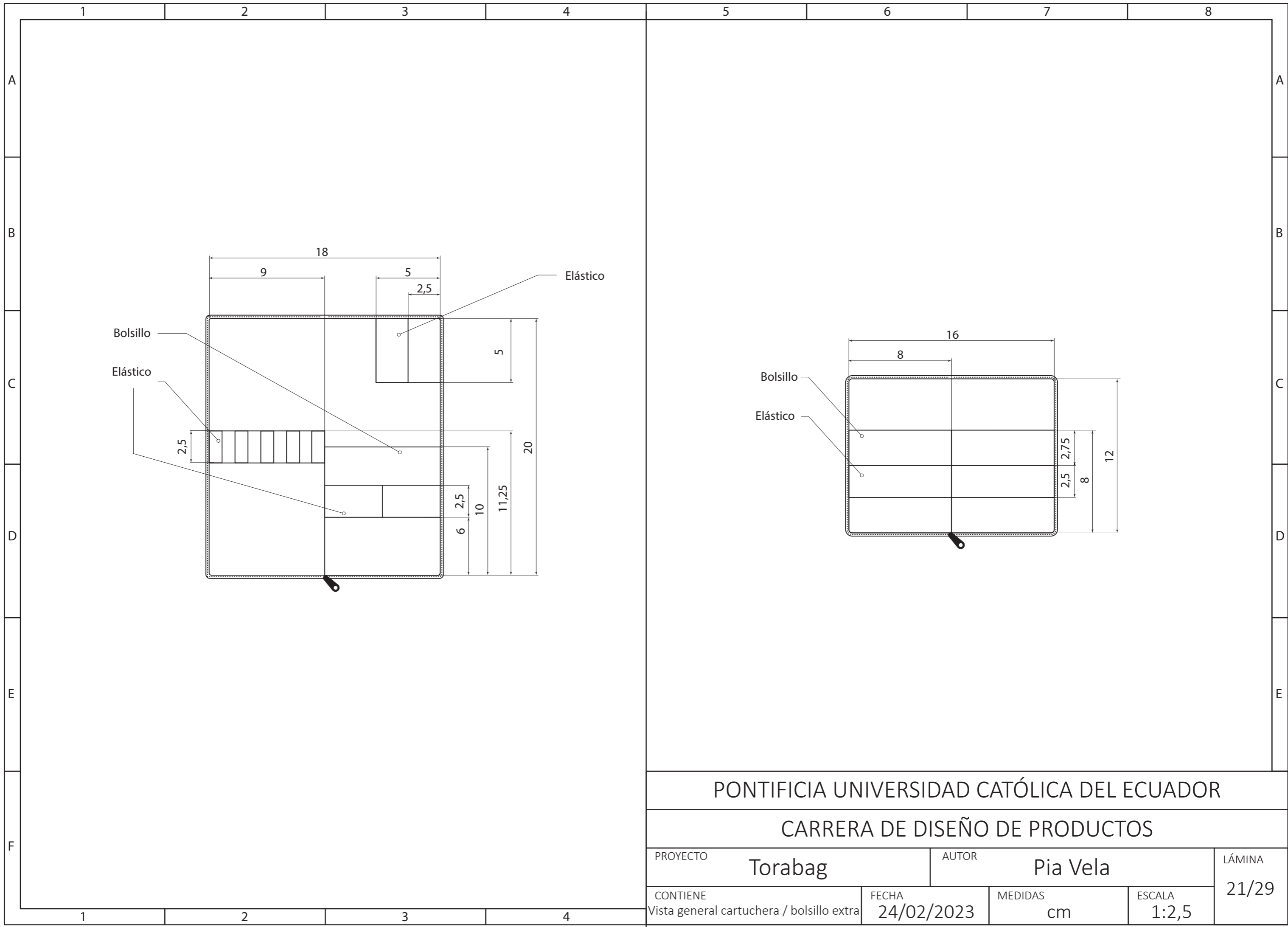

PONTIFICIA UNIVERSIDAD CATÓLICA DEL ECUADOR

CARRERA DE DISEÑO DE PRODUCTOS

PROYECTO	Torabag	AUTOR	Pia Vela	LÁMINA	21/29
CONTIENE	Vista general cartuchera / bolsillo extra	FECHA	24/02/2023	MEDIDAS	
				ESCALA	1:2,5

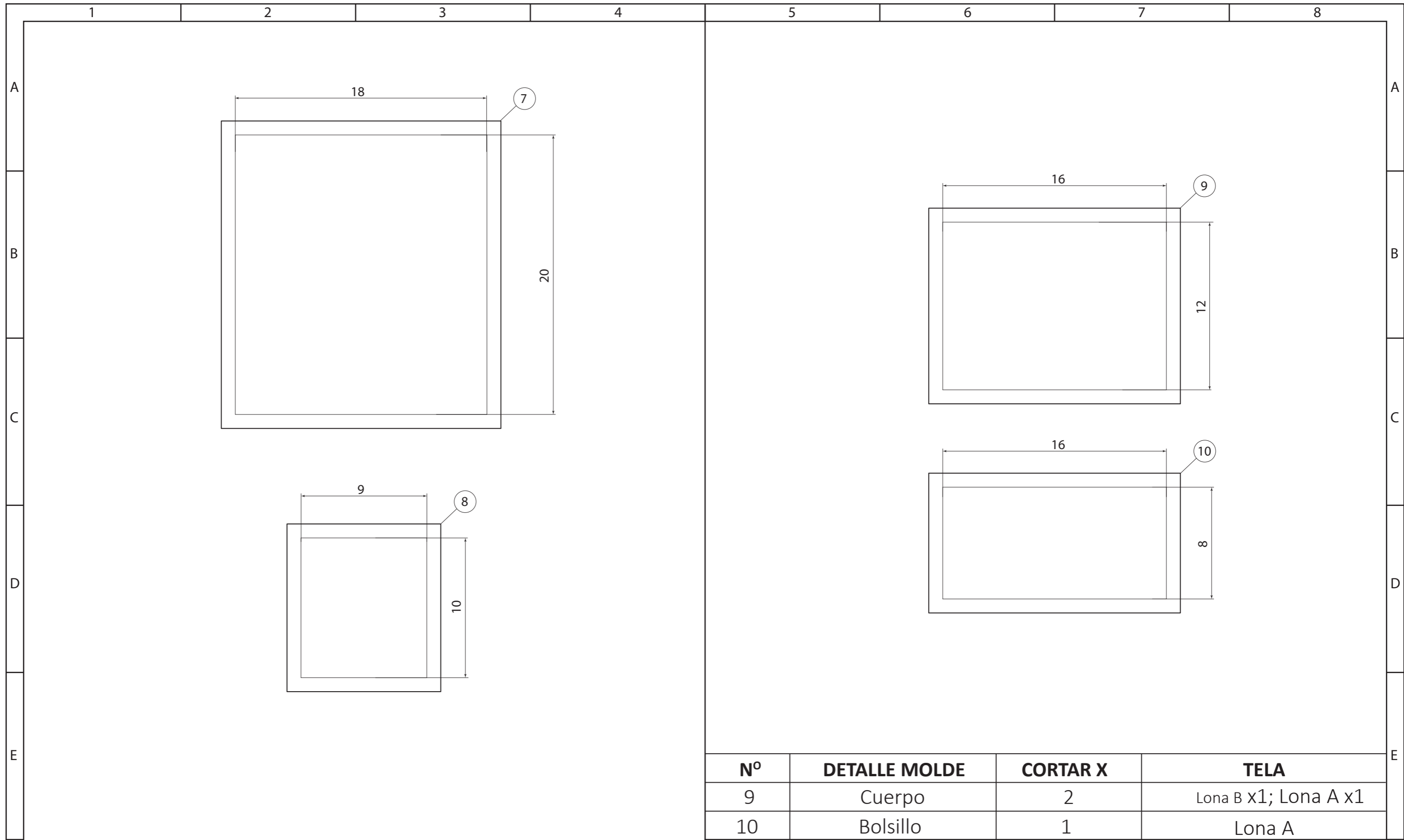

Nº	DETALLE MOLDE	CORTAR X	TELA
9	Cuerpo	2	Lona B x1; Lona A x1
10	Bolsillo	1	Lona A

PONTIFICIA UNIVERSIDAD CATÓLICA DEL ECUADOR

CARRERA DE DISEÑO DE PRODUCTOS

Nº	DETALLE MOLDE	CORTAR X	TELA
7	Cuerpo	2	Lona B x1; Lona A x1
8	Bolsillo 10cm	1	Lona A

PROYECTO	Torabag	AUTOR	Pia Vela	LÁMINA	22/29
CONTIENE	Despiece cartuchera/ bolsillo extra	FECHA	24/02/2023	MEDIDAS	
		ESCALA	1:2,5		

	1	2	3	4	5	6	7	8	
A									A
B									B
C									C
D									D
E									E
F									F
	1	2	3	4					

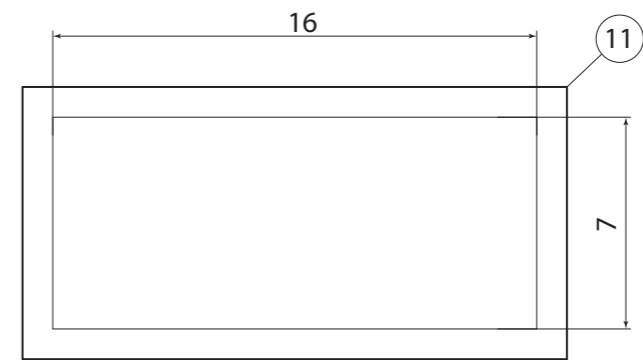
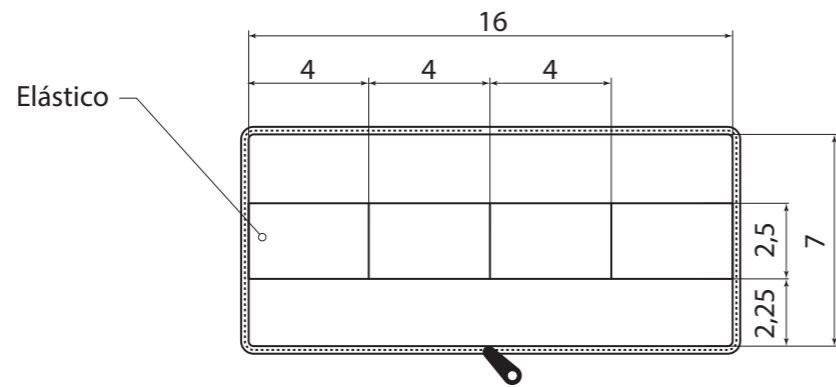

Nº	DETALLE MOLDE	CORTAR X	TELA
11	Cuerpo	2	Lona B x1; Lona A x1
PONTIFICIA UNIVERSIDAD CATÓLICA DEL ECUADOR			
CARRERA DE DISEÑO DE PRODUCTOS			
PROYECTO	Torabag		AUTOR Pia Vela
CONTIENE	Vista general / despiece bolsillo USB	FECHA	24/02/2023
MEDIDAS	cm	ESCALA	1:2,5
			LÁMINA 23/29

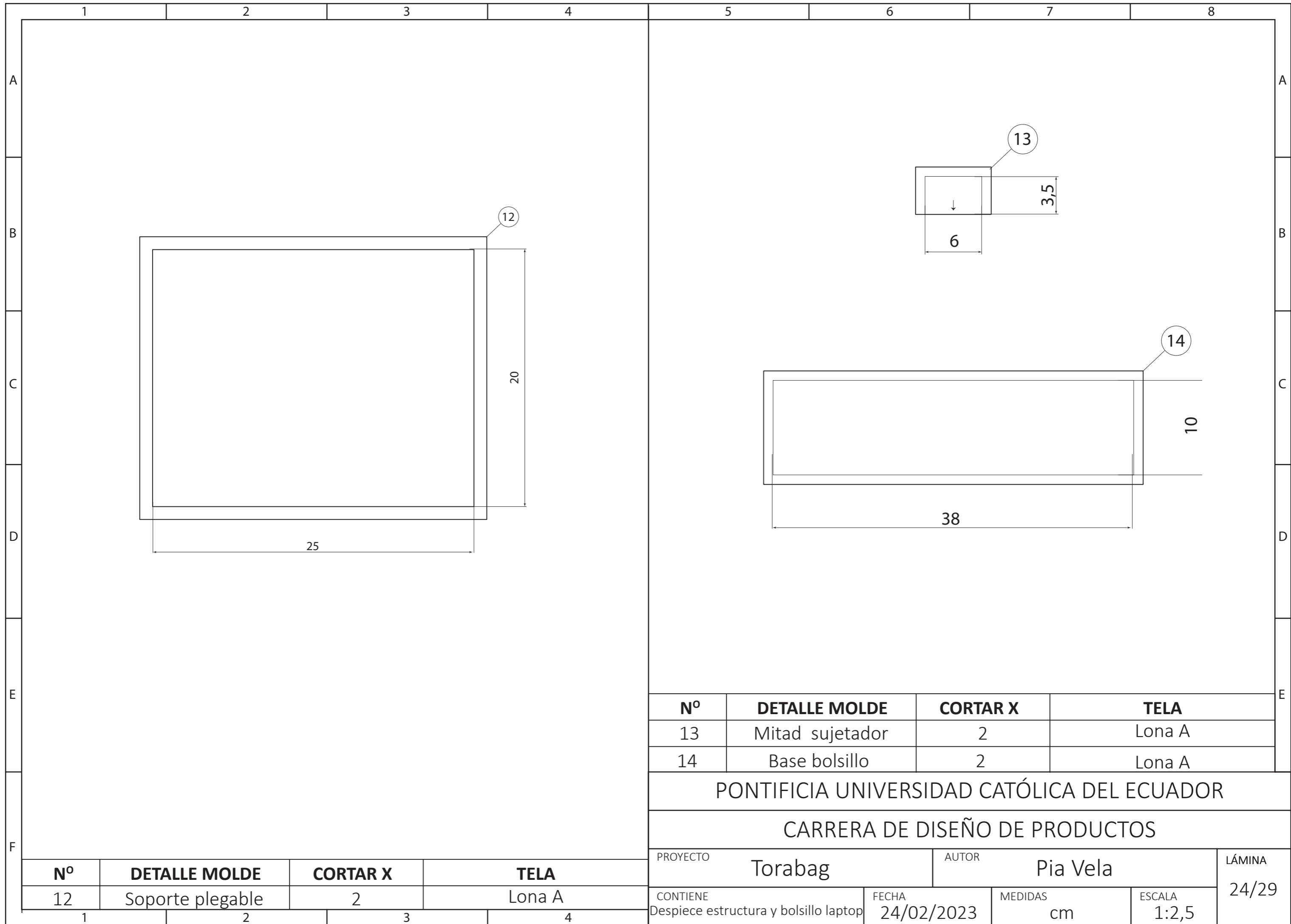

Nº	DETALLE MOLDE	CORTAR X	TELA
13	Mitad sujetador	2	Lona A
14	Base bolsillo	2	Lona A

PONTIFICIA UNIVERSIDAD CATÓLICA DEL ECUADOR

CARRERA DE DISEÑO DE PRODUCTOS

PROYECTO	Torabag	AUTOR	Pia Vela	LÁMINA
CONTIENE	Despiece estructura y bolsillo laptop	FECHA	24/02/2023	24/29
MEDIDAS	cm	ESCALA	1:2,5	

Nº	DETALLE MOLDE	CORTAR X	TELA
12	Soporte plegable	2	Lona A

1	2	3	4	5	6	7	8									
TEJIDOS																
NOMBRE COMERCIAL	COMPOSICIÓN	ANCHO	PRECIO X METRO	PROVEEDOR	UBICACIÓN	TONO A	TONO B									
Lona	100% algodón	160	\$5,90	Casa de las telas	1-3, 5-14	kaki safari / Azul índigo	Palo de rosa / morado									
Tотора	-	varas de 2cm ^{+/-0,2}	\$12 por todas las piezas	Tотора Wasi	1, 2, 12, 14	Crudo	Crudo									
AVÍOS																
NOMBRE COMERCIAL	COMPOSICIÓN	PRECIO	PROVEEDOR	CANTIDAD	UBICACIÓN	CROMÁTICA 1	CROMÁTICA 2									
Cadena cierre continua	Poliester	\$0,15 x m	La casa del cierre	2,5 metros	1, 4, 7, 9, 11	G8 o C4	E12 o D1									
Deslizador	Poliester	\$0,10 c/u	La casa del cierre	6	1, 4, 7, 9, 11	G8 o C4	E12 o D1									
Elástico 4 cm	Nylon	FALTA	Insumoda	35 cm	11, 18	Negro	Negro									
Elástico 2,5 cm	Nylon	FALTA	Insumoda	35 cm	11, 18	Negro	Negro									
Ganchos impresión 3D	PLA	\$1 c/u	Bacteria Lab	2	En bolsillo pantalla laptop	Negro	Negro									
Etiqueta	Algodón	\$0,10 c/u	Marcas_etiquetas	1	3, frontal	Crudo/tinta negra	Crudo/tinta negra									
Reata algodón 2,5	100% algodón	\$1,25 x m	Insumoda	3 metros	3 Frontal y posterior entreteji- da con la totora	Tinte iris No.47 kaki safari	Tinte iris No.17 Azul oscuro									
<p>PONTIFICIA UNIVERSIDAD CATÓLICA DEL ECUADOR</p> <p>CARRERA DE DISEÑO DE PRODUCTOS</p> <table border="1" style="width: 100%; border-collapse: collapse;"> <tr> <td style="width: 50%;">PROYECTO Torabag</td> <td style="width: 50%;">AUTOR Pia Vela</td> <td style="width: 10%; text-align: center;">LÁMINA</td> </tr> <tr> <td style="width: 50%;">CONTIENE Ficha de materiales estuche</td> <td style="width: 15%;">FECHA 24/02/2023</td> <td style="width: 10%;">MEDIDAS cm</td> </tr> <tr> <td colspan="2"></td> <td style="text-align: center;">ESCALA -</td> </tr> </table>								PROYECTO Torabag	AUTOR Pia Vela	LÁMINA	CONTIENE Ficha de materiales estuche	FECHA 24/02/2023	MEDIDAS cm			ESCALA -
PROYECTO Torabag	AUTOR Pia Vela	LÁMINA														
CONTIENE Ficha de materiales estuche	FECHA 24/02/2023	MEDIDAS cm														
		ESCALA -														

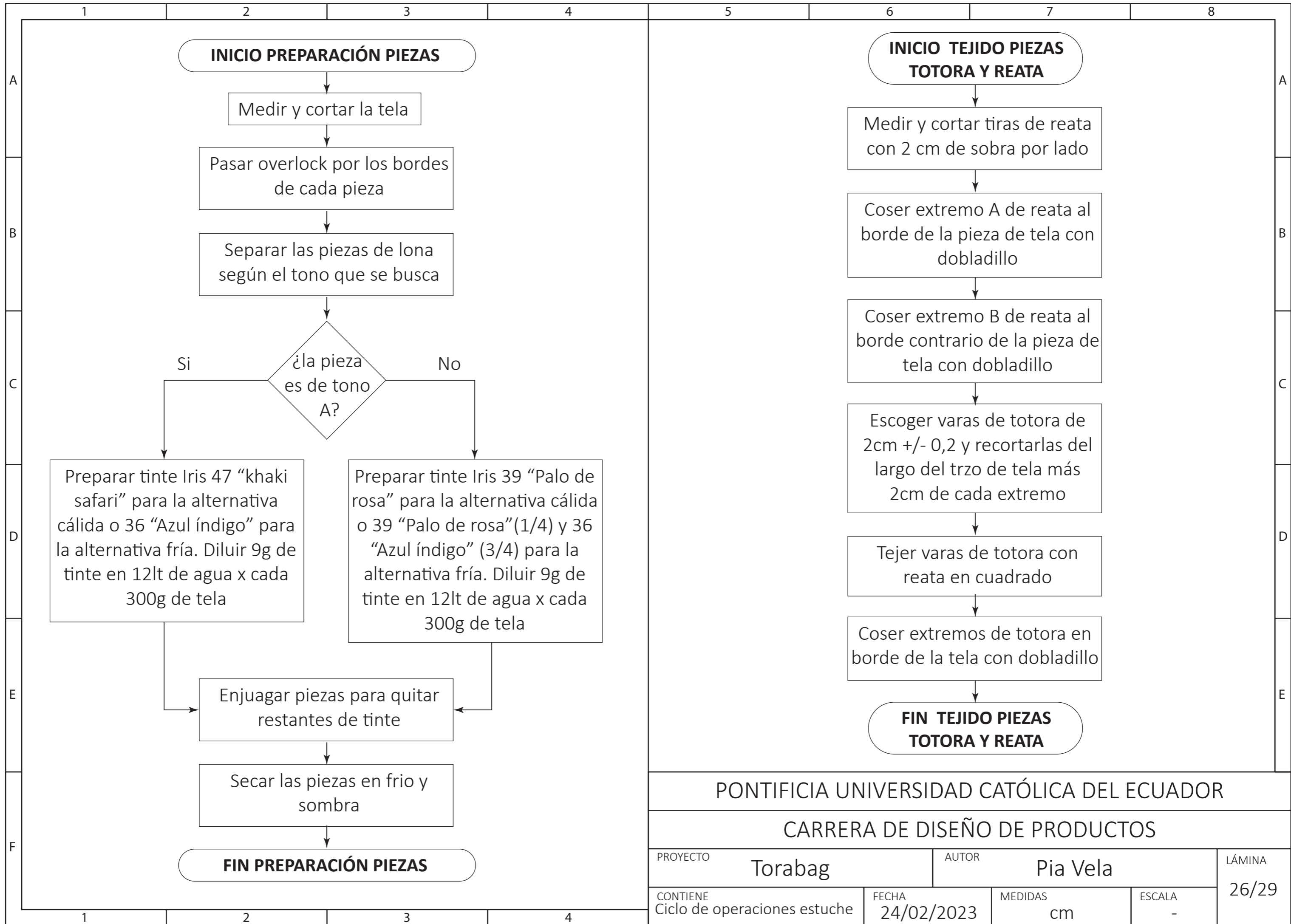

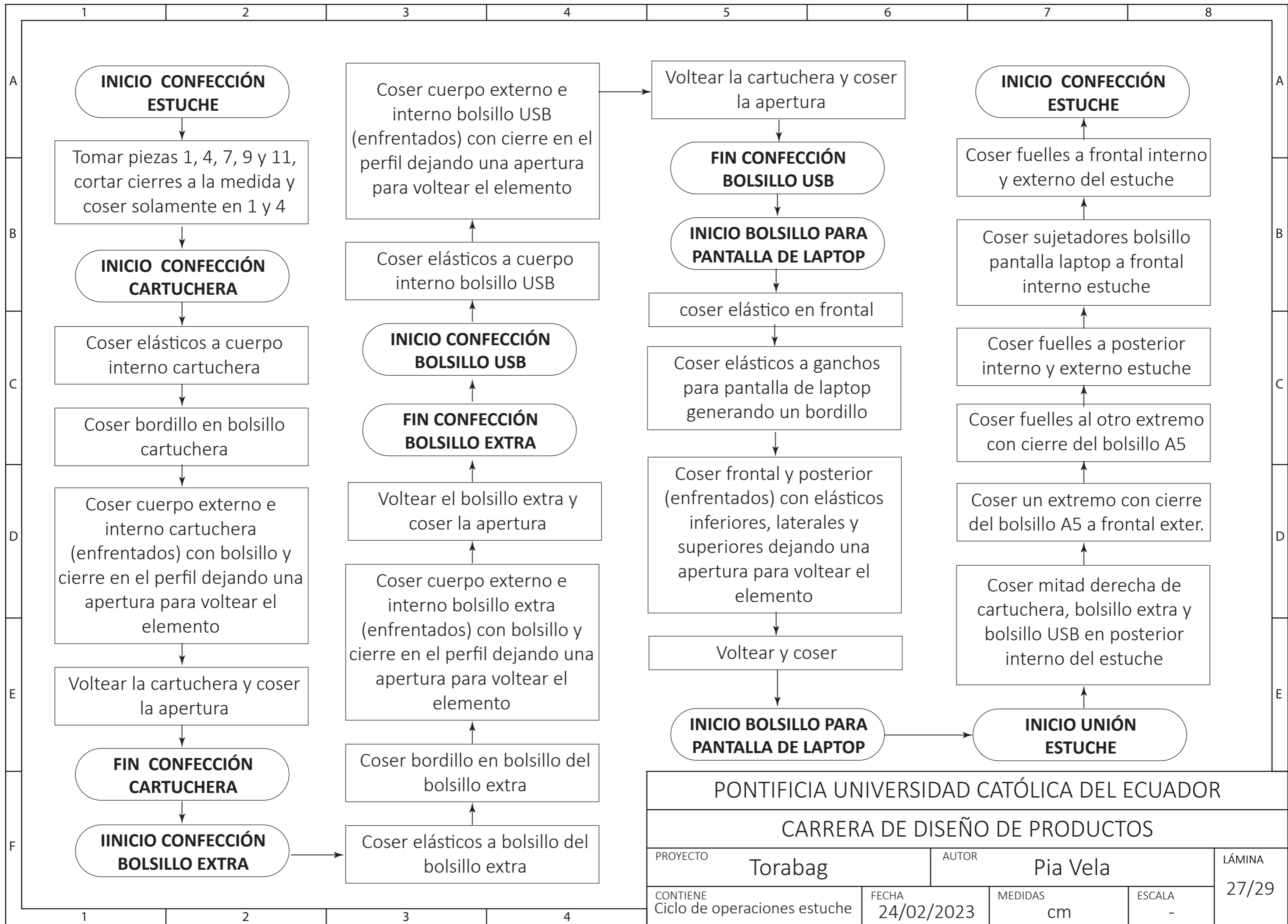

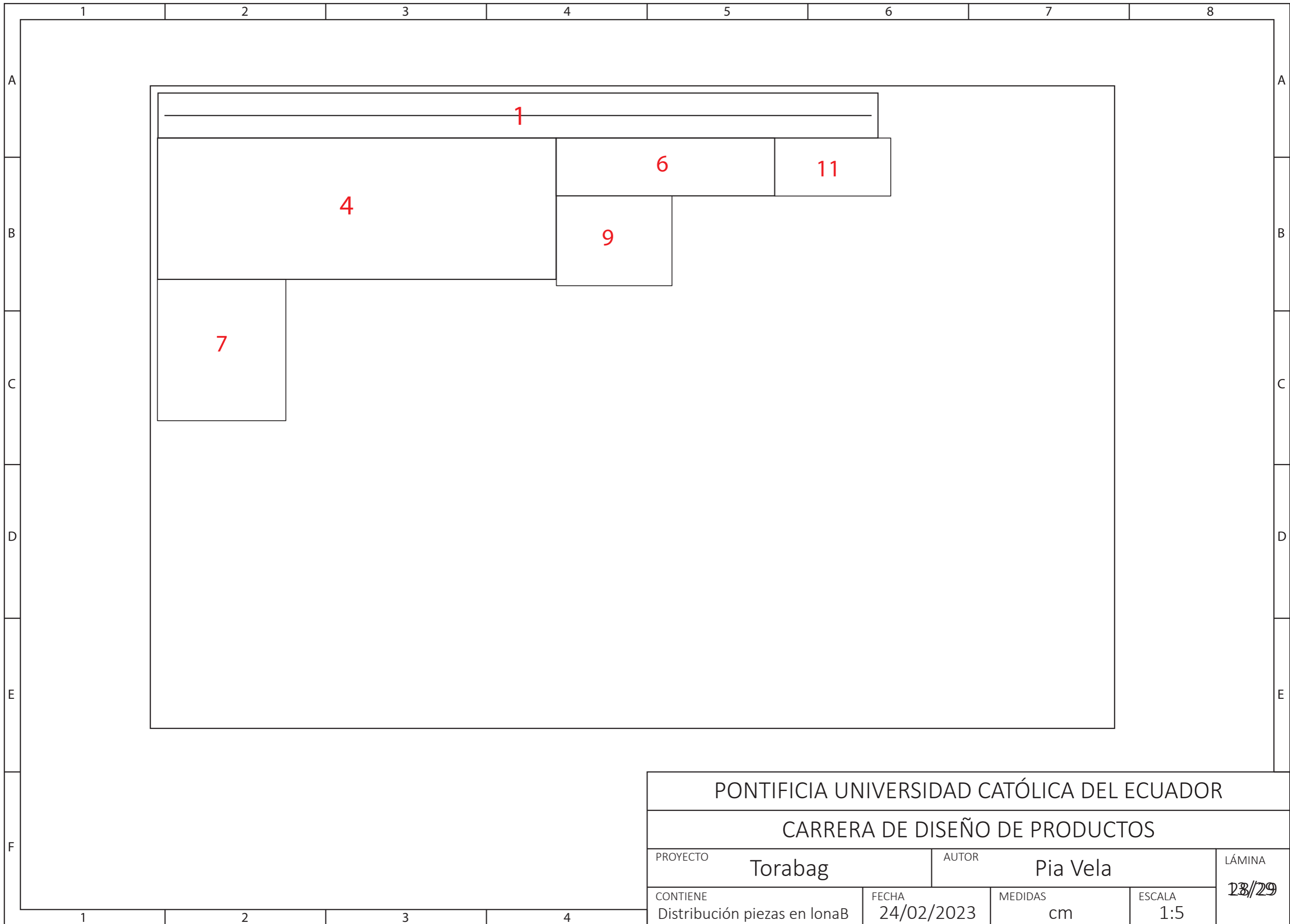

PONTIFICIA UNIVERSIDAD CATÓLICA DEL ECUADOR				
CARRERA DE DISEÑO DE PRODUCTOS				
PROYECTO	Torabag		AUTOR	Pia Vela
CONTIENE	Distribución piezas en lonaB		FECHA	24/02/2023
			MEDIDAS	cm
			ESCALA	1:5
			LÁMINA	13/29

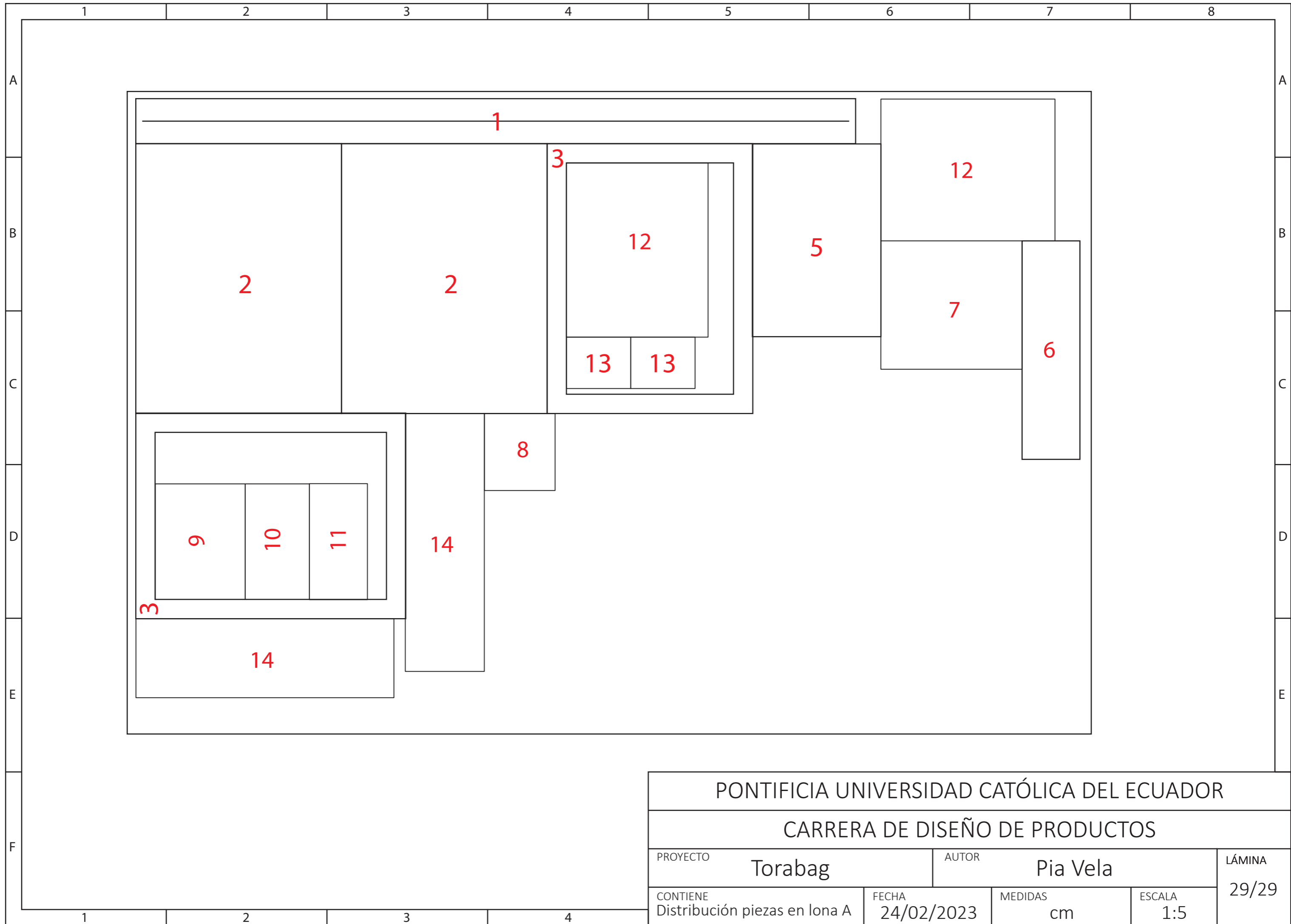

PONTIFICIA UNIVERSIDAD CATÓLICA DEL ECUADOR

CARRERA DE DISEÑO DE PRODUCTOS

PROYECTO	Torabag	AUTOR	Pia Vela	LÁMINA	29/29
CONTIENE	Distribución piezas en lona A	FECHA	24/02/2023	MEDIDAS	cm
				ESCALA	1:5